



SKOOT·X

EB0162 Rev 00

Automated Digital Radiography

SAFETY WARNINGS / PRECAUTIONS

KEEP THIS MANUAL – DO NOT LOSE

THIS MANUAL IS PART OF THE **SKOOT • X** SYSTEM AND MUST BE RETAINED FOR THE LIFE OF THE PRODUCT. PASS ON TO SUBSEQUENT OWNERS.

Ensure any amendments are incorporated with this document.



WARNING! The **SKOOT • X** is designed for a specific use. Using the **SKOOT • X** outside of its intended use is dangerous. Failure to comply with the warnings, instructions, and specifications in this manual could result in **SEVERE INJURY** or **DEATH**. Read and understand this manual before using.



WARNING! ELECTRICAL CORDS CAN BE HAZARDOUS.

Misuse can result in **FIRE** or **DEATH** by **ELECTRICAL SHOCK**. Inspect thoroughly before each use. Do **NOT** use if damaged. Do **NOT** use when wet. Keep away from water. Do **NOT** drive, drag or place objects over cord.



WARNING! Do **NOT** operate scanner in an explosive environment. Do **NOT** operate scanner in the presence of volatile substances.



WARNING! If this product is to be used with any Child Products listed in (*Chapter 2.2*), be sure to read and comply with the warnings, instructions, and specifications in the Child Product's User Manual(s).



WARNING! DO NOT DISASSEMBLE. No user-serviceable parts. Disassembling any of the components in this product, beyond the instructions in this user manual, could void the regulatory certifications and/or effect the safety of the product.



WARNING! MAGNETIC MATERIAL. The wheels of the crawler produce an extremely strong magnetic field which may cause failure or permanent damage to items such as watches, memory devices, CRT monitors, medical devices or other electronics.



Tools, magnets and metal objects can cut, pinch or entrap hands and fingers. **HANDLE WITH CARE.**

People with pacemakers or ICD's must stay at least 25 cm (10 in) away.

WARNING! MAGNETIC MATERIAL. The handheld controller produces a strong magnetic field which may cause failure or permanent damage to items such as watches, memory devices, CRT monitors, medical devices or other electronics.

People with pacemakers or ICD's must stay at least 10 cm (4 in) away.

WARNING! MAGNETIC MATERIAL. The installation/removal mat (see "Installation/Removal Mat" on page 20) contains magnetic material.

People with pacemakers or ICD's must stay at least 10 cm (4 in) away.



CAUTION! DO NOT operate the **SKOOT • X** crawler on an inspection surface which is electrically connected to a component that is being welded.



CAUTION! DO NOT DISCONNECT UNDER LOAD. Shut off power before connection or disconnecting. Permanent damage to electronics could occur.



EMERGENCY STOP. This symbol indicates emergency stop button.



The WEEE symbol indicates that the product must not be disposed of as unsorted municipal waste, but should be collected separately.

(see *Disposal* on page 86 for additional details).

TABLE OF CONTENTS

1	Identification	2
	1.1. Product Brand	2
	1.2. Manufacturer	2
	1.3. Compliance Declarations	2
	1.3.1. ISED Emissions Compliance (Canada).....	2
	1.3.2. FCC Suppliers Declaration of Conformity (United States).....	2
	1.3.3. European Union CE Declarations	3
	1.3.4. UKCA Declarations	3
2	Product Specifications	4
	2.1. Base SKOOT•X System	4
	2.1.1. Intended Use	4
	2.1.1.1. Operating Limits	4
	2.1.1.2. Operating Environment	4
	2.1.1.3. User	5
	2.1.2. Unintended Use	5
	2.1.3. Dimensions and Weight	5
	2.1.4. Power Requirements	6
	2.1.5. Environmental Sealing	6
	2.1.6. Performance Specifications	6
	2.1.7. Encoder Interface Specifications	7
	2.2. Child Products	7
	2.2.1. Battery Kit	7
3	Definitions	8
	3.1. Definition of Symbols	8
	3.2. Safety Symbols	8
	3.3. Safety Signal Words	9
4	System components	10
	4.1. Component Identification	10

4.1.1.	Base System	10
4.1.2.	Child Products	11
4.2.	Tools	12
4.2.1.	Included Tools	12
4.3.	Base System Components	12
4.3.1.	Crawler - Chain System	12
4.3.2.	Crawler - Magnetic System	13
4.3.2.1	Connections	14
4.3.2.2	Emergency Off Button	14
4.3.3.	Power Controller	15
4.3.3.1	AC/DC Power Supply	16
4.3.4.	Handheld Controller	17
4.3.5.	Umbilical	18
4.3.6.	Auxiliary Cable	18
4.3.7.	Detector Bracket	18
4.3.8.	Source Cart	18
4.3.9.	Chain Link	19
4.3.10.	Red Dovetail Link	19
4.3.11.	Buckle	19
4.3.12.	Cable Management	19
4.3.13.	Installation/Removal Mat	20
4.3.14.	Tools	20
4.3.15.	Cases	20
4.4.	Child Products	20
4.4.1.	Battery Kit	20

5	Preparation for Use	21
5.1.	Preparation for Magnetic System Transportation	21
5.2.	Preparation of Inspection Surface (Magnetic System)	21
5.3.	Configurations	22
5.3.1.	Chain System	22
5.3.2.	Magnetic System	24
5.4.	Crawler	26
5.4.1.	Umbilical	26
5.4.2.	Handle	26
5.4.3.	Emergency Off Button	27
5.4.4.	Handheld Controller	28
5.4.5.	Magnetic Mounts	28
5.5.	Detector Bracket	29
5.5.1.	Attaching Detector to the Detector Bracket	29
5.5.2.	Mounting Detector Bracket to Crawler	30

5.5.3.	Positioning the Detector	32
5.5.4.	Adjusting Detector Height	33
5.5.5.	Adjusting the Detector Angle	33
5.6.	Source Cart	34
5.6.1.	Releasing the Mounting Plate	34
5.6.2.	Attaching the Mounting Plate	34
5.6.3.	Mounting Plate	35
5.7.	Connecting Chain & Dovetail Links	36
5.7.1.	Connecting Chain Links	36
5.7.2.	Disconnecting Chain Links	36
5.7.3.	Disconnecting the Red Dovetail Links	37
5.8.	Cable Management	38
5.8.1.	Cable Management Dovetail Mount	38
5.8.2.	Cable Management Setup	38
5.8.3.	Clamp Setup	39
5.9.	Backpack	40
5.9.1.	Mounting a Backpack	40
5.9.2.	Using the backpack	41

6

Operation 42

6.1.	System Startup	42
6.2.	Placement of Crawler on Inspection Surface	44
6.2.1.	Chain System.....	44
6.2.2.	Magnetic System	49
6.2.2.2	Scanner Installation/Removal Mat Use	49
6.2.2.3	Detector Setup	51
6.2.2.4	Crawler Position.....	51
6.3.	Operation	52
6.3.1.	Handheld Controller Layout	52
6.3.1.1	Touchscreen	52
6.3.1.2	D-pad	53
6.3.1.3	Joysticks	53
6.3.2.	Mode Select Screen	53
6.3.3.	Jog Mode	54
6.3.4.	Latched Jog Mode	55
6.3.5.	1 Axis Scan Mode.....	56
6.3.5.1	1 Axis Scan Setup Screen	56
6.3.5.2	1 Axis Scan Screen	57
6.3.6.	System Utilities Screen	59
6.3.6.1	User Settings Screen	60
6.3.6.2	Diagnostics Screens	61

6.3.6.2.1. Detected Modules	61
6.3.6.2.2. System 1	62
6.3.6.2.3. System 2	63
6.3.6.2.4. System 3	63
6.3.6.2.5. Skoot-X	64
6.3.6.3 Touch Calibration Screen	65
6.3.6.4 Joystick Calibration Screen	66
6.3.6.5 Draw	67
6.3.7. High Internal Temperature Screen	67

7 Maintenance	69
7.1. Safety Precautions Before Maintenance	69
7.2. Cleaning	69
7.3. Maintenance Schedule	70

8 Troubleshooting	71
8.1. Startup Issues	71
8.1.1. Joystick Off Centre	71
8.1.2. Checking Network	71
8.2. Startup Override	72
8.2.1. Scan Devices	73
8.2.2. Reset Parameters	74
8.2.3. System Parameters	74
8.2.4. Device Address.....	74
8.3. Additional Issues	75

9 Service and Repair	76
9.1. Technical Support	76

10 Spare Parts	77
10.1. Crawler	77
10.2. Crawler (Magnetic)	78
10.3. Kit Components	79
10.3.1. Power Cord Type	81
10.3.2. Detector Bracket Type	81
10.4. Backpack	83
10.5. Installation/Removal Mat	83
10.6. Cases	84
10.7. Accessories	85
10.7.1. Cable Management, Dovetail Mount	85

11 Disposal86

12 Limited Warranty87

13 Appendix89

 13.1. SKOOT•X Chain Configuration Setup Chart89

IDENTIFICATION

1.1. Product Brand

The **SKOOT•X** is a remotely operated vehicle suitable for driving on ferrous and non-ferrous material. Its primary purpose is to perform inspections of assets such as pipes or small vessels by moving a detector and source around a surface.

1.2. Manufacturer

Distributor:

Manufacturer:

Jireh Industries Ltd.

53158 Range Road 224
Ardrossan, Alberta T8E 2K4
Canada

Phone: 780.922.4534

jireh.com

1.3. Compliance Declarations

1.3.1. ISED Emissions Compliance (Canada)

CAN ICES-003(A) / NMB-003(A)

This Class A digital apparatus complies with Canadian ICES-003.

Cet appareil numérique de la classe A est conforme à la norme NMB-003 du Canada.

1.3.2. FCC Suppliers Declaration of Conformity (United States)

This device complies with Part 15 of the FCC Rules. Operation is subject to the following two conditions: (1) this device may not cause harmful interference, and (2) this device must accept any interference received, including interference that may cause undesired operation.

This equipment has been tested and found to comply with the limits for a Class A digital device, pursuant to part 15 of the FCC Rules. These limits are designed to provide reasonable protection against harmful interference when the equipment is operated in a commercial environment. This equipment generates, uses, and can radiate radio frequency energy and, if not installed and used in accordance with the instruction manual, may cause harmful interference to radio communications. Operation of this equipment in a residential area is likely to cause harmful interference in which case the user will be required to correct the interference at his own expense.

RESPONSIBLE PARTY NAME:	Jireh Industries
ADDRESS:	2955 S Sam Houston Pkwy E Suite 300 Houston, Texas United States 77047
TELEPHONE:	832-564-0626

1.3.3. European Union CE Declarations

Jireh Industries hereby declares that the SKOOT•X product complies with the essential requirements and other relevant provisions of the following European Union directives:



- 2014/30/EU EMC Directive
- 2014/35/EU Low Voltage Directive
- 2012/19/EU Directive on Waste Electrical and Electronic Equipment
- 2011/65/EU Directive on Restriction of Hazardous Substances (RoHS)

1.3.4. UKCA Declarations

Jireh Industries hereby declares that the SKOOT•X product complies with the essential requirements and other relevant provisions of the following UK directives.



Title	Edition/Date of Issue
Electromagnetic Compatibility Regulations	2016
Electrical Equipment (Safety) Regulations	2016
Waste Electrical and Electronic Equipment Regulations	2013
Restriction of the Use of Certain Hazardous Substances in Electrical and Electronic Equipment Regulations	2012

PRODUCT SPECIFICATIONS

2.1. Base SKOOT•X System

This section outlines the product specifications of the base system.

2.1.1. Intended Use

The **SKOOT•X**'s primary purpose is to perform inspections of assets such as pipes, or small vessels by moving a detector and source around a surface. It is intended for industrial use only.

2.1.1.1 Operating Limits

Category	Parameter	Specification
Inspection Surface	Condition	Clean, free of excess rust, scale, debris (<i>i.e. dirt, sand, etc.</i>), ice, frost
	Minimum OD	203 mm (8.0 in)
	Maximum OD (<i>Chain system</i>)	1067 mm (42 in)
	Maximum surface temperature	50°C (122°F)
Scanner	Maximum umbilical length	30 m (100 ft)
	Maximum source payload <i>(performance may vary with surface conditions)</i>	29 kg (65 lbs)

2.1.1.2 Operating Environment

The SKOOT•X is for use in dry industrial environments having ambient temperatures shown below. It is **NOT** intended for use in explosive environments.

Category	Parameter	Specification
Environment	Minimum ambient temperature	-20°C (-4°F)
	Maximum ambient temperature	50°C (122°F)

2.1.1.3 User

The SKOOT • X is intended to be used by persons who have read and understand the user manual. The intended user is to be a person without limitations in the physical abilities of the upper and lower limbs, sight, or hearing.

2.1.2. Unintended Use

The SKOOT • X is NOT intended for:

- ▶ use outside of its intended use
- ▶ unattended use
- ▶ lifting / lowering objects or people (i.e. using the SKOOT • X as a crane / elevator)
- ▶ driving into / over obstructions, excluding standard weld caps
- ▶ installation on a surface on which welding is actively occurring

2.1.3. Dimensions and Weight

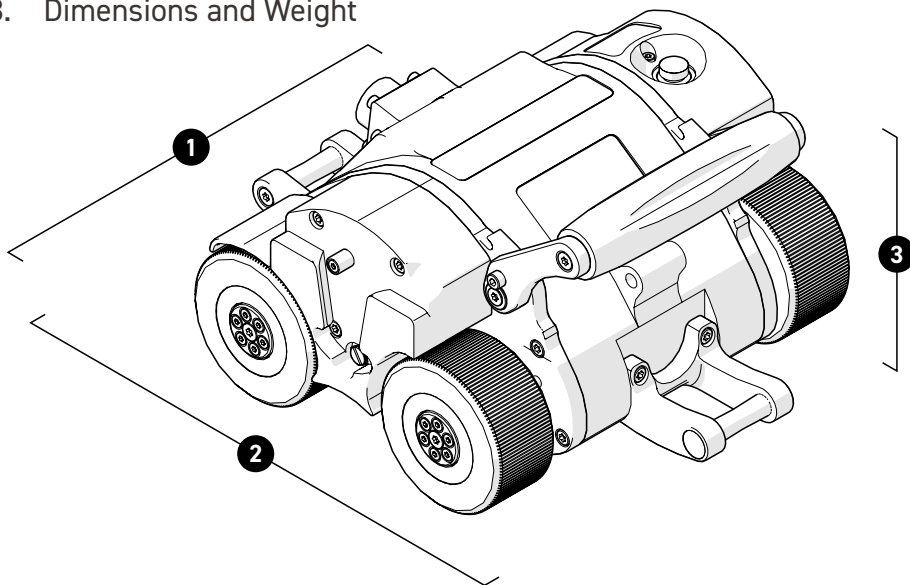

Fig. 1 - Crawler dimensions

1	Crawler width:	20.6 cm	8.1 in
2	Crawler depth:	26.2 cm	10.3 in
3	Crawler height:	14.7 cm	5.8 in
	Crawler weight:	4.6 kg	10.1 lb

2.1.4. Power Requirements



WARNING! A reliable power source must be used to power the crawler. Connections must be secured to prevent accidental disconnection. Power failure may cause the crawler to freewheel down when operating in a vertical orientation. Portable generator usage is not recommended unless accompanied by the use of an uninterruptible power controller.



WARNING! Proper grounding of the power controller is important for safe operation. When a generator is used to supply power to the system (*not recommended*), the generator must be properly grounded (*refer to generator manual*).



CAUTION! DO NOT DISCONNECT UNDER LOAD. Shut off power before connection or disconnecting. Permanent damage to electronics could occur.



CAUTION! Power must be supplied from an approved JIREH power source.

Input Voltage: 25-45VDC

Input Power: 320 W

2.1.5. Environmental Sealing

Dust-tight, watertight (*not submersible*).

2.1.6. Performance Specifications

Category	Parameter	Specification
Crawler	Maximum speed	7.4 cm/sec (2.9 in/sec)
	Encoder resolution, idler	220.4 counts/mm (5,598.4 counts/in)

2.1.7. Encoder Interface Specifications

Output type: 4 channel quadrature 5VDC RS422 compatible.

Power: Power must be supplied to the interface.

5VDC +/-10% power limited to < 15w.

1	Enc B
2	Enc B'
3	Enc A
4	Enc A'
5	Aux Enc A'
6	Aux Enc A
7	Aux Enc B'
8	Aux Enc B
9	Enc +5V
10	Enc Com
H	Shield

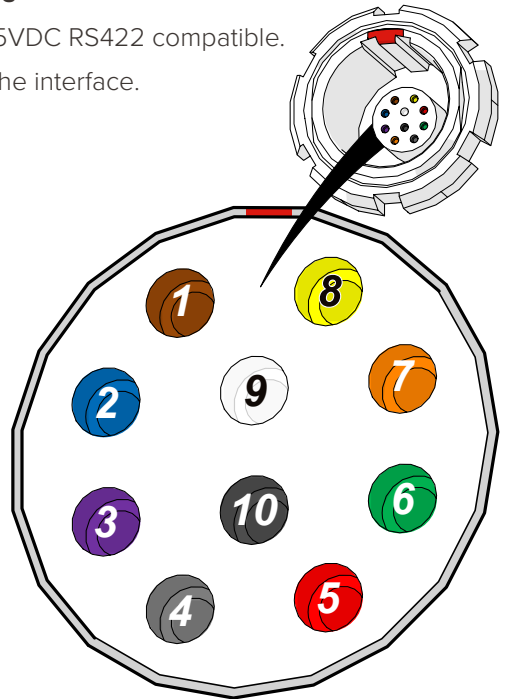

Fig. 2 - JIREH Industries pin out configuration

2.2. Child Products

The products listed in this section integrate with the base system to perform certain tasks. Their use may modify the product specifications (*i.e. intended use, power requirements, etc.*) from those of the base system. These products have a user manual of their own and shall be referred to for their product specifications as well as how their use modifies the product specifications of the base system.

2.2.1. Battery Kit DVG001-

The battery provides portable power to the crawler.

DEFINITIONS

3.1. Definition of Symbols



Instructions to 'look here' or to 'see this part'.

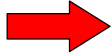

Denotes movement. Instructing users to carry out an action in a specified direction.

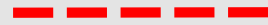

Indicates alignment axis.



Alerts the user that the view has changed to a reverse angle.

3.2. Safety Symbols

The following safety symbols might appear on the product and in this document. Read and understand their meaning below:



General warning symbol

This symbol is used to alert the user to potential hazards. All safety messages that follow this symbol shall be obeyed to avoid possible harm or material damage.



Shock hazard caution symbol

This symbol is used to alert the user to potential electric shock hazards. All safety messages that follow this symbol shall be obeyed to avoid possible harm.

3.3. Safety Signal Words

The following safety signal words might appear in this document. Read and understand their meaning below:

DANGER!

The DANGER signal word indicates an imminently hazardous situation. It calls attention to a procedure, practice, or the like that if not correctly performed or adhered to will result in death or serious personal injury. Do not proceed beyond a DANGER signal word until the indicated conditions are fully understood and met.

WARNING!

The WARNING signal word indicates a potentially hazardous situation. It calls attention to a procedure, practice, or the like that if not correctly performed or adhered to could result in death or serious personal injury. Do not proceed beyond a WARNING signal word until the indicated conditions are fully understood and met.

CAUTION!

The CAUTION signal word indicates a potentially hazardous situation. It calls attention to a procedure, practice, or the like that if not correctly performed or adhered to may result in minor or moderate personal injury, material damage, particularly to the product, destruction of part or all of the product, or loss of data. Do not proceed beyond a CAUTION signal word until the indicated conditions are fully understood and met.

SYSTEM COMPONENTS

4.1. Component Identification

4.1.1. Base System

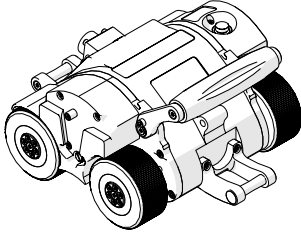

Fig. 3 - SK00T-X crawler (chain system)
EBA005

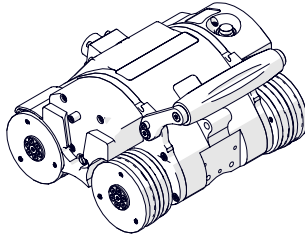

Fig. 4 - SK00T-X crawler (magnetic system)
EBA011

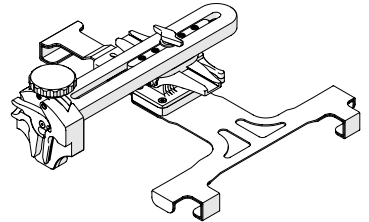

Fig. 5 - Detector bracket
EBA001-

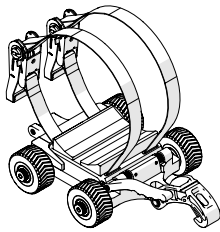

Fig. 6 - Source cart
EBA009

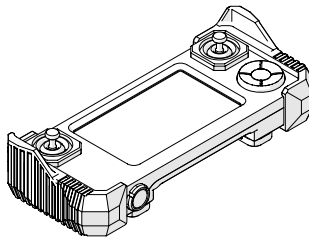

Fig. 7 - Handheld controller
DMA006

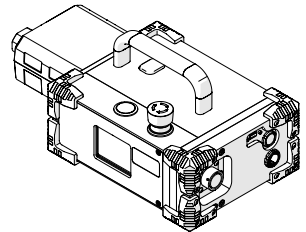

Fig. 8 - Power controller
CXA040-

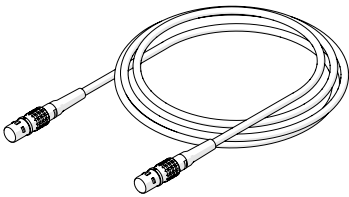

Fig. 9 - Auxiliary cable
UMA017-

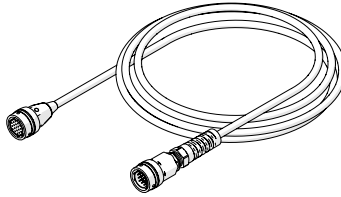

Fig. 10 - Umbilical
UMA022-

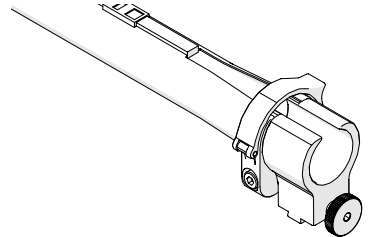

Fig. 11 - Cable management
CES044-

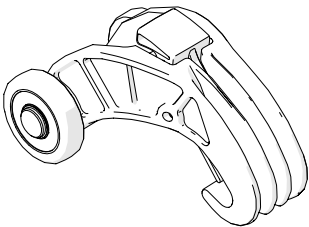

Fig. 12 - Chain link
EES004

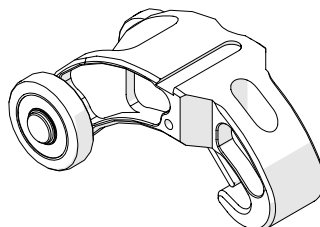

Fig. 13 - Red dovetail link
EES011

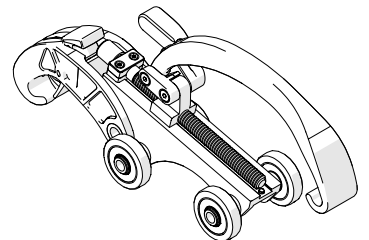

Fig. 14 - Buckle
EBS042-

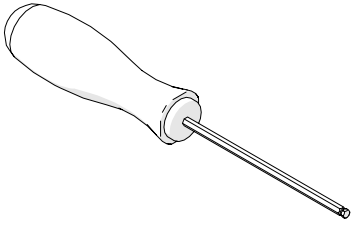

Fig. 15 - 3 mm hex wrench
EA414

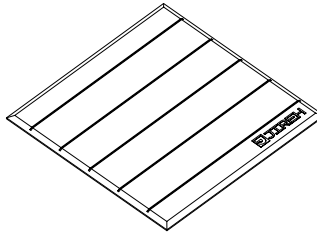

Fig. 16 - Installation/removal mat
AAS061

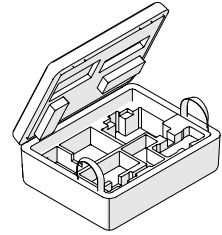

Fig. 17 - SK00T-X crawler case
EBA007

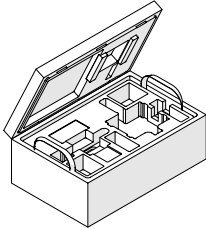

Fig. 18 - SK00T-X case
EBA010

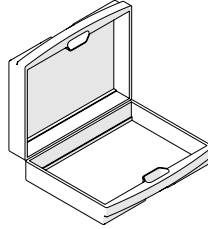

Fig. 19 - SK00T-X case
EA421

4.1.2. Child Products

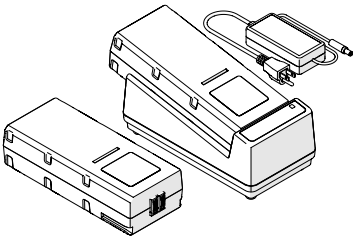

Fig. 20 - Battery Kit
DVG001-

4.2. Tools

4.2.1. Included Tools

The included 3 mm hex driver (Fig. 21) is suitable for typical **SKOOT•X** adjustments.

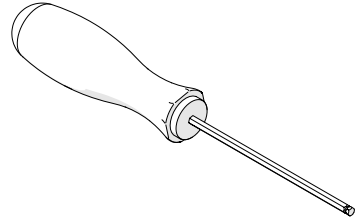

Fig. 21 - 3 mm hex driver

4.3. Base System Components

4.3.1. Crawler - Chain System

The crawler includes the motor encoder, umbilical connections and accessory mounting point. The crawler is affixed with chain connection points and non-magnetic wheels.

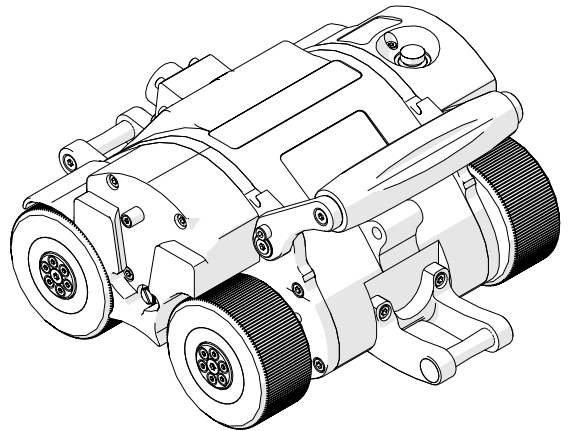

Fig. 22 - Crawler (chain)

4.3.2. Crawler - Magnetic System



WARNING! MAGNETIC MATERIAL. The wheels of the crawler produce an extremely strong magnetic field which may cause failure or permanent damage to items such as watches, memory devices, CRT monitors, medical devices or other electronics. People with pacemakers or ICD's must stay at least 25 cm (10 in) away.

The crawler includes the motor encoder, umbilical connections and accessory mounting point. The crawler includes magnetic wheels.

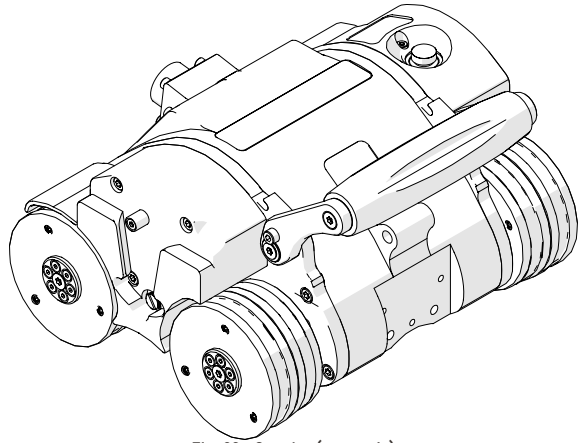

Fig. 23 - Crawler (magnetic)

4.3.2.1 Connections

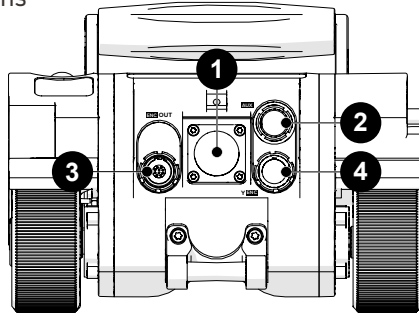

Fig. 24 - Crawler connections

1	Umbilical connection	Connection for the umbilical.
2	AUX	Connection for an auxiliary device.
3	ENC OUT	Encoder output connection.
4	Y ENC	Connection for a 2 nd encoder axis input or motorized module connection. The device connected to the Y-ENC 8-pin Lemo® has its encoder signals passed through as the 2nd encoder axis on the encoder output connectors.

4.3.2.2 Emergency Off Button

The red button on the top left of the crawler provides an emergency off button to the entire system. When pressed, all power to the **SKOOT•X** system will disengage.

To restore system power, press the power button on the power controller (see “Power Controller” on page 15).



Fig. 25 - Emergency off

NOTE: Terminating system power may cause the crawler to freewheel around a pipe.

4.3.3. Power Controller



CAUTION! DO NOT DISCONNECT UNDER LOAD. Shut off power before connection or disconnecting. Permanent damage to electronics could occur.



WARNING! There are no user serviceable components inside the power controller. Dangerous voltages can be present inside the case. Do **NOT** open. Return to manufacturer for repair.

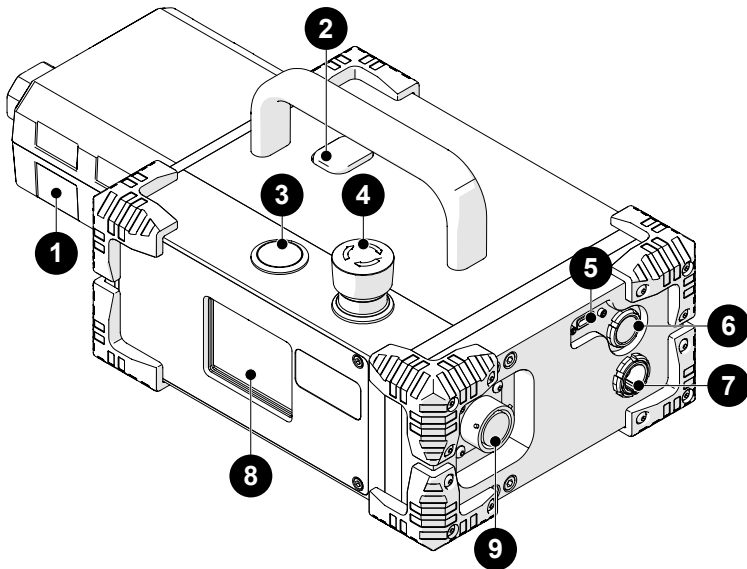

Fig. 26 - Power controller

The power controller accepts 25-45VDC power from the AC/DC power supply or battery. A start/stop safety circuit, and physical **ON** and **OFF** push-buttons are integrated into the power controller.

- | | | |
|----------|--------------------|--|
| 1 | AC/DC power supply | Connect the plug from a properly grounded source. Use IEC320 cord approved for AC/DC power supply. |
| 2 | Release button | Unlatch the AC/DC power supply or battery from the power controller. |

3	Power button	Activate system power by pressing (<i>and releasing</i>) the silver button.
4	Stop button	The red stop button latches down when pressed. This stop button shuts down the system. Twist the stop button clockwise to return to the released position. This must be done before power can be activated.
5	SCANLINK™ connector	Connection for SCANLINK devices.
6	CTRL socket	Connection for the auxiliary cable.
7	ENC socket	Connection for the encoder cable.
8	Status LCD	Power controller status display.
9	Umbilical connection	Connection for the umbilical.

In the event of a break in the stop circuit (*the stop circuit runs through the power controller cable, umbilical and the crawler's emergency stop button*), the power will shut off.

NOTE: Before use, always inspect the power cable and plug for damage. The power controller should not be used if visible damage is present. The use of damaged components may be a safety hazard.

4.3.3.1 AC/DC Power Supply

The 1 AC/DC power supply (*Fig. 26*) is used to connect the power controller to a suitable 100-240VAC, 50/60Hz grounded power source capable of supplying a minimum of 5 amps.

The safety of the power controller relies on the provision of a proper ground connection.

In environments with moisture present, a GFCI (*Ground Fault Circuit Interrupter*) must be used to ensure operator safety.

NOTE: Some generators or DC-AC inverters may introduce significant levels of noise to the system. This may degrade overall system performance or reduce the system life expectancy. The use of generators or DC-AC inverters is not recommended and is used at the operator's risk.

4.3.4. Handheld Controller



WARNING! MAGNETIC MATERIAL. The handheld controller contains magnetic material. Those with pacemakers or ICD's must stay at least 10 cm (4 in) away.



CAUTION! DO NOT DISCONNECT UNDER LOAD. Shut off power before connection or disconnecting. Permanent damage to electronics could occur.

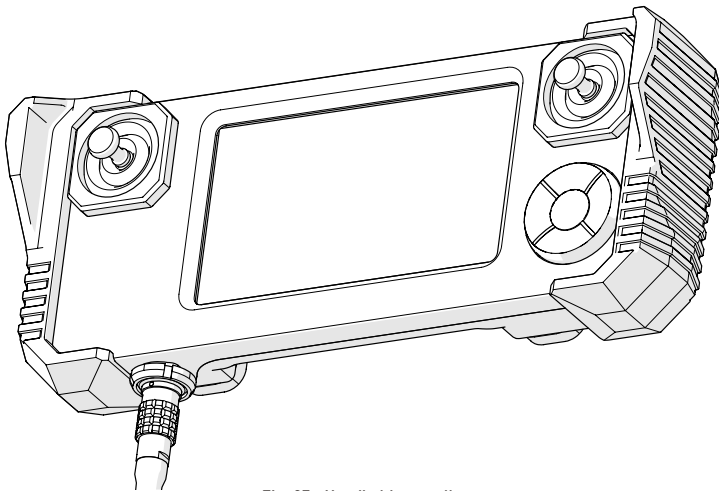

Fig. 27 - Handheld controller

The handheld controller is used to manipulate a scanner installed on an inspection surface. User settings and scan information are edited using the handheld controller. The handheld controller is connected to the power controller with the auxiliary cable.

The handheld controller utilizes a resistive touch screen. Care should be taken not to use sharp or gritty objects on the screen as the touch membrane can scratch. If the screen is damaged, all programmed functions can still be accessed using the D-pad.

NOTE: Do **NOT** connect the handheld controller while the system is activated.

4.3.5. Umbilical

The umbilical provides the power, network distribution as well and encoder signal transmission between the crawler and the power controller.

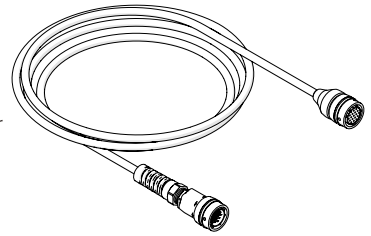

Fig. 28 - Umbilical

4.3.6. Auxiliary Cable

The auxiliary cable connects the handheld controller to the power controller. 36VDC and network signals are used in the cable.

Both auxiliary cable connectors are identical and interchangeable. The cable may be plugged into the 4-pin receptacle on the power controller or the crawler's umbilical.

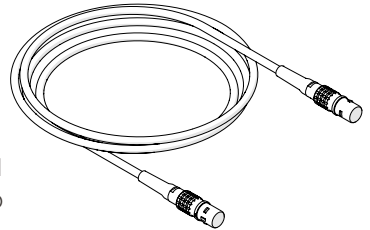

Fig. 29 - Auxiliary cable

NOTE: *Inspect the cable and connectors for damage before use. When any damage is evident, the cable must **NOT** be utilized. The use of a damaged cable may be a safety hazard and could also put other system components at risk.*

4.3.7. Detector Bracket

Holds the detector in place.

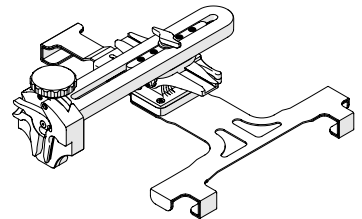

Fig. 30 - Detector bracket

4.3.8. Source Cart

Holds the source in place.

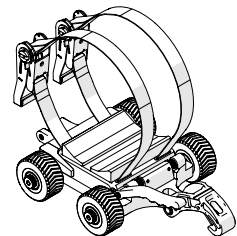

Fig. 31 - Source cart

4.3.9. Chain Link

The chain links connect to assemble the required length to mount the system to a pipe.

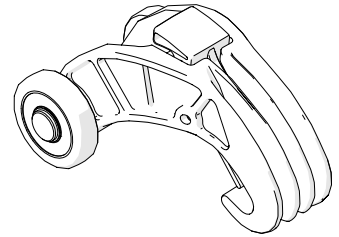

Fig. 32 - Chain link

4.3.10. Red Dovetail Link

The red dovetail link provides a mounting point for the cable management.

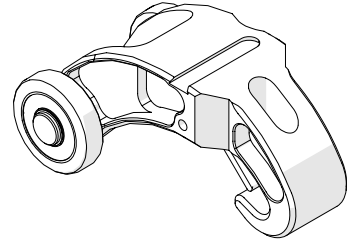

Fig. 33 - Red dovetail link

4.3.11. Buckle

The buckle offers adjustment of the chain link tension as well as provides the connection point of the chain assembly.

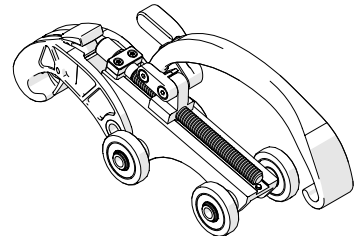

Fig. 34 - Buckle

4.3.12. Cable Management

The cable management provides a means of protecting and organizing cables, tubes and hoses.

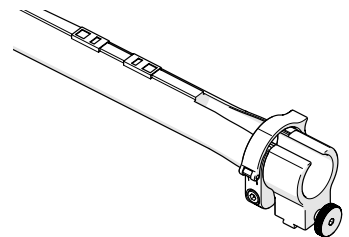

Fig. 35 - Cable management

4.3.13. Installation/Removal Mat



WARNING! MAGNETIC MATERIAL. The installation/removal mat contains magnetic material. Those with pacemakers or ICD's must stay at least 10 cm (4 in) away.



The installation/removal mat is used for the installation and removal of motorized magnetic-wheeled scanners from the inspection surface. A motorized scanner can drive on/off the mat while the integrated magnets in the mat hold it firmly in place on the inspection surface.

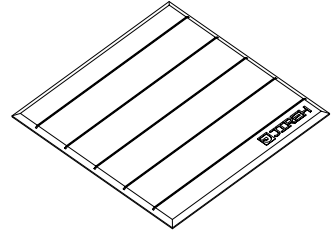

Fig. 36 - Installation/removal mat

4.3.14. Tools

The hex driver is included for various scanner and accessory adjustments (see "Tools" on page 12 for additional details).

4.3.15. Cases

Rugged carrying cases provide protection for the system.

4.4. Child Products

4.4.1. Battery Kit

The rechargeable battery provides portable power to the crawler and components.

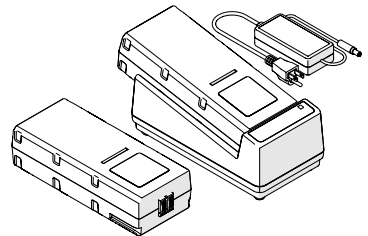

Fig. 37 - Battery kit

PREPARATION FOR USE

5.1. Preparation for Magnetic System Transportation



CAUTION! PINCH / CRUSH HAZARD. BE CAREFUL when passing the **SKOOT • X** crawler through narrow ferrous (*magnetic*) openings, such as man-holes. The magnetic drive wheels can cause bodily harm if allowed to slam onto the walls of the opening.

5.2. Preparation of Inspection Surface (Magnetic System)

- ▶ Remove build-up of scale and other debris (*i.e. dirt, ice*) from the surface on which the crawler is to drive. Excessive build-up will cause the wheels to lose magnetic attraction, which may lead to wheel slippage or crawler detachment.
- ▶ Ensure that no obstructions (*other than standard butt welds*) or voids are in the drive path. Obstructions and voids could cause the crawler to fall if driven into or over.
- ▶ Ensure that there are no patches of non-ferrous material in the drive path of the crawler. If the crawler drives over a non-ferrous patch, it will lose magnetic attraction and will cause the crawler to fall.

5.3. Configurations

5.3.1. Chain System

BOM ID	Description
1	Source cart
2	Chain link
3	Crawler (chain)
4	Detector bracket
5	Umbilical
6	Red dovetail link
7	Cable management
8	Buckle
9	Auxiliary cable
10	Power controller
11	Handheld controller
12	Power supply

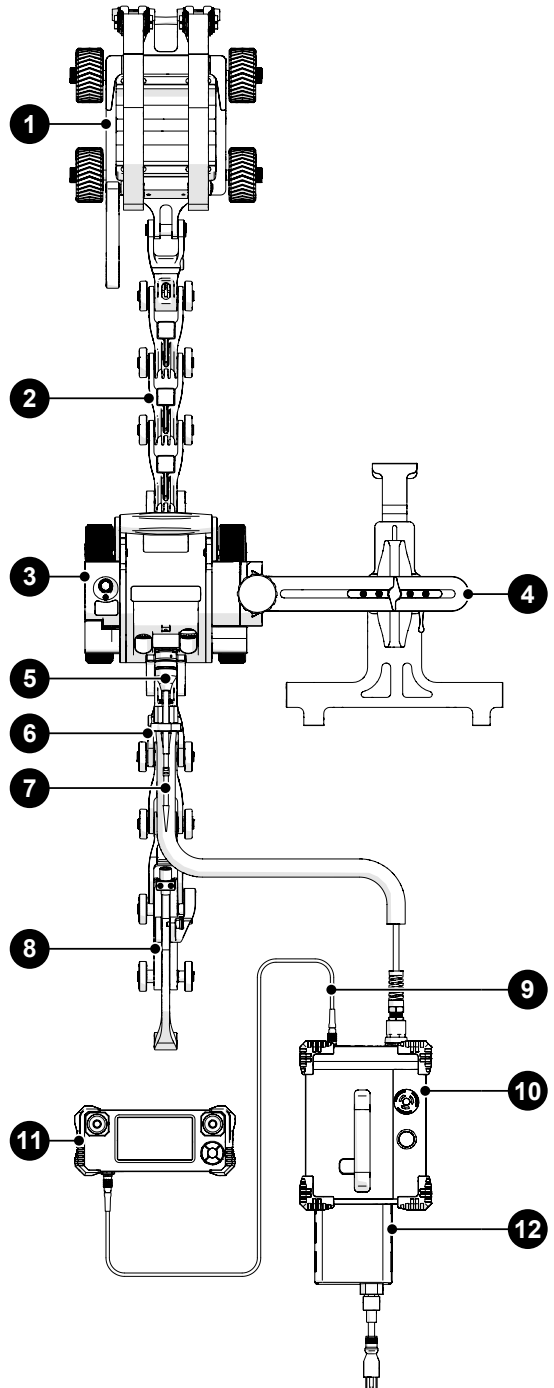

Fig. 38 - Chain system connectivity

To configure the **SKOOT•X** chain system for scanning, follow these steps:



CAUTION! DO NOT DISCONNECT

UNDER LOAD. Shut off power before connection or disconnecting. Permanent damage to electronics could occur.



1. Mount the source in the **1** source cart (see “Source Cart” on page 34).
2. Assemble the appropriate chain configuration to the **3** crawler (see “SKOOT•X Chain Configuration Setup Chart” on page 89).
3. Mount a detector to the **4** detector bracket (see “Attaching Detector to the Detector Bracket” on page 29).
4. Attach the **4** detector bracket to the **3** crawler (see “Mounting Detector Bracket to Crawler” on page 30).
5. Connect the **10** power controller to the **3** crawler using the **5** umbilical.
6. Connect the **11** handheld controller to the **10** power controller using the **9** auxiliary cable.
7. Insert **12** AC/DC power supply into the **10** power controller.

5.3.2. Magnetic System

BOM ID	Description
1	Crawler (magnetic)
2	Detector bracket
3	Umbilical
4	Auxiliary cable
5	Handheld controller
6	Power controller
7	Power supply

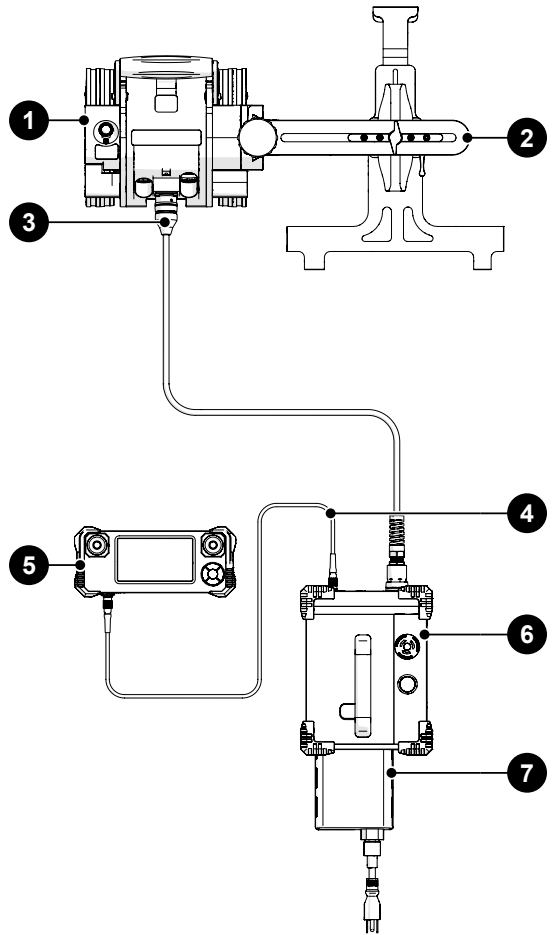



Fig. 39 - Magnetic system connectivity

To configure the **SKOOT•X** magnetic system for scanning, follow these steps:

 **CAUTION! DO NOT DISCONNECT UNDER LOAD.** Shut off power before connection or disconnecting. Permanent damage to electronics could occur.



1. Mount a detector to the **2** detector bracket (see “Attaching Detector to the Detector Bracket” on page 29).
2. Attach the **2** detector bracket to the **1** crawler (see “Mounting Detector Bracket to Crawler” on page 30).
3. Connect the **6** power controller to the **1** crawler using the **3** umbilical.
4. Connect the **5** handheld controller to the **6** power controller using the **4** auxiliary cable.
5. Insert **7** AC/DC power supply into the **6** power controller.

5.4. Crawler

5.4.1. Umbilical

To mount the umbilical to the crawler, follow these steps:

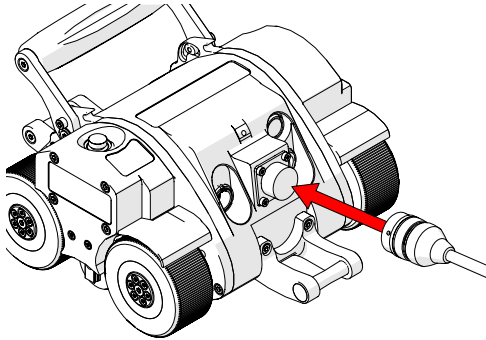

Fig. 40 - Connect to umbilical

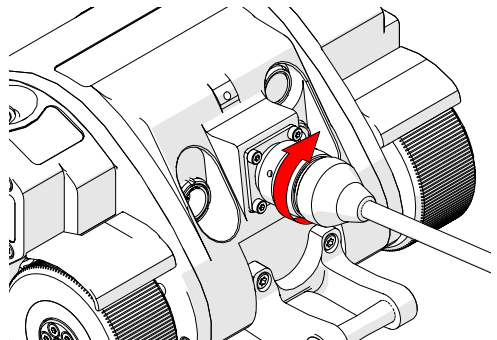

Fig. 41 - Align with crawler's umbilical mount

1. Align the pins of the umbilical to the connector at the rear of the **SKOOT•X** (Fig. 40).
2. Twist the umbilical's sleeve clockwise, locking the umbilical in place (Fig. 41).

5.4.2. Handle

The handle can be lowered when required.

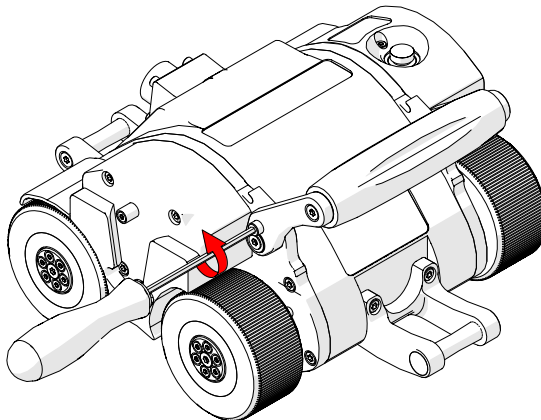

Fig. 42 - Unscrew handle lock screw

1. To lower the handle, use the supplied 3 mm driver to loosen the handle lock screws on either side of the handle (Fig. 42).

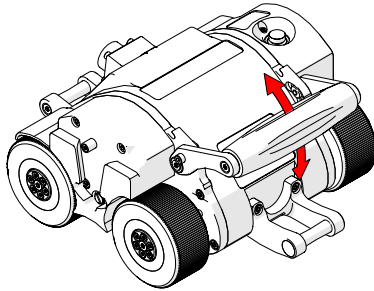

Fig. 43 - Pivot handle as desired

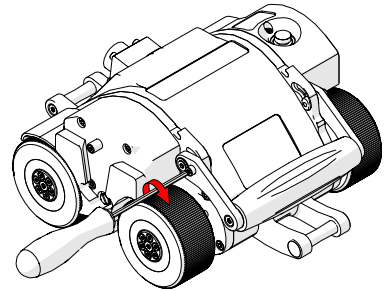

Fig. 44 - Tighten lock screws

2. Pivot the handle as required (*Fig. 43*).
3. Tighten the handle lock screws when complete (*Fig. 44*).

5.4.3. Emergency Off Button

The red button located on the top left of the crawler provides an emergency off button to the entire system. When pressed, all power to the **SKOOT•X** system will disengage.

To restore system power, it is necessary to press the power button located on the power controller (*see "Power Controller" on page 15*).



Fig. 45 - Emergency off

5.4.4. Handheld Controller



WARNING! MAGNETIC MATERIAL. The handheld controller contains magnetic material. Those with pacemakers or ICD's must stay at least 10 cm (4 in) away.



CAUTION! DO NOT DISCONNECT UNDER LOAD. Shut off power before connection or disconnecting. Permanent damage to electronics could occur.



5.4.5. Magnetic Mounts

Magnetic mounts on the rear of the handheld controller assist in preventing the handheld controller from falling.

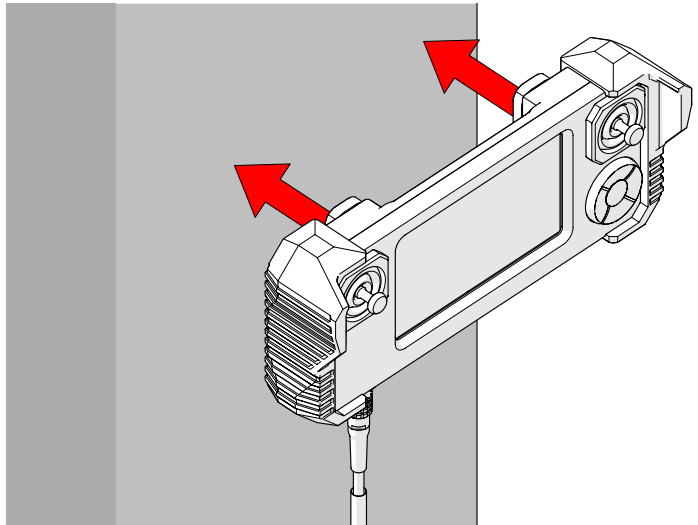

Fig. 46 - Handheld controller attaches to ferrous surfaces

5.5. Detector Bracket

5.5.1. Attaching Detector to the Detector Bracket

To attach a detector, follow these steps:

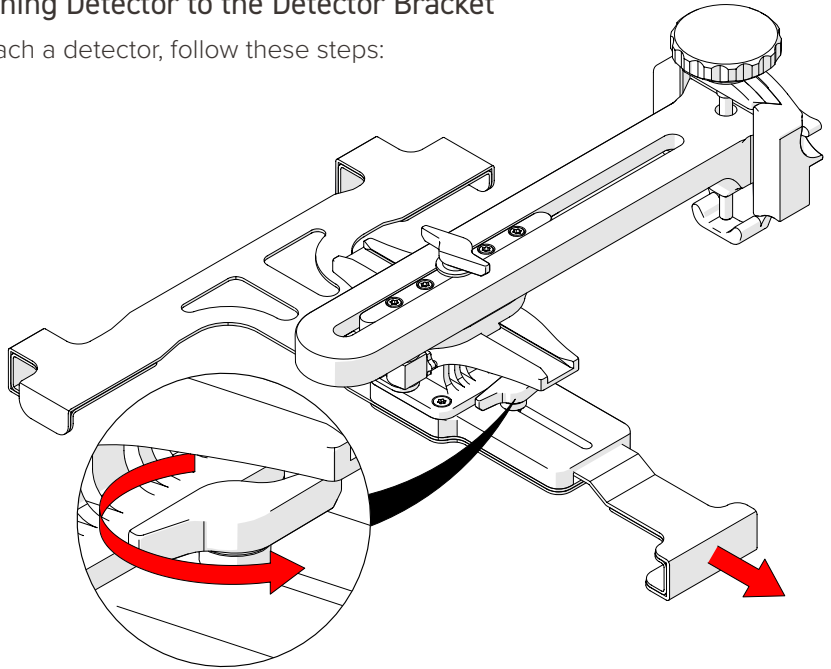

Fig. 47 - Loosen red knob to extend detector bracket's clamp arm

1. Loosen the red knob to extend the detector bracket's clamp arm.

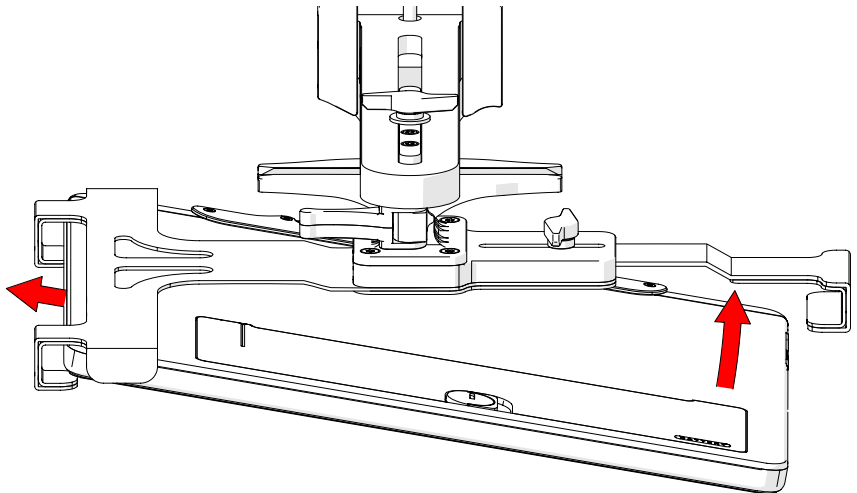

Fig. 48 - Place detector within the tabs of the detector holder

2. Position the detector within the tabs of the detector bracket (Fig. 48).

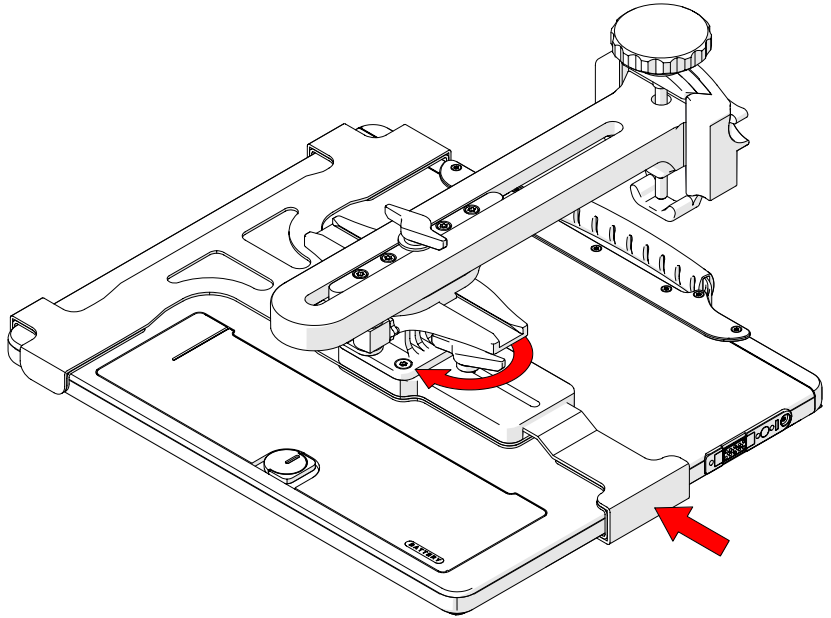

Fig. 49 - Press clamp arm around detector and tighten red knob

3. Press the clamp arm around the detector and tighten the red knob.

5.5.2. Mounting Detector Bracket to Crawler

To mount the detector bracket to the crawler, follow these steps:

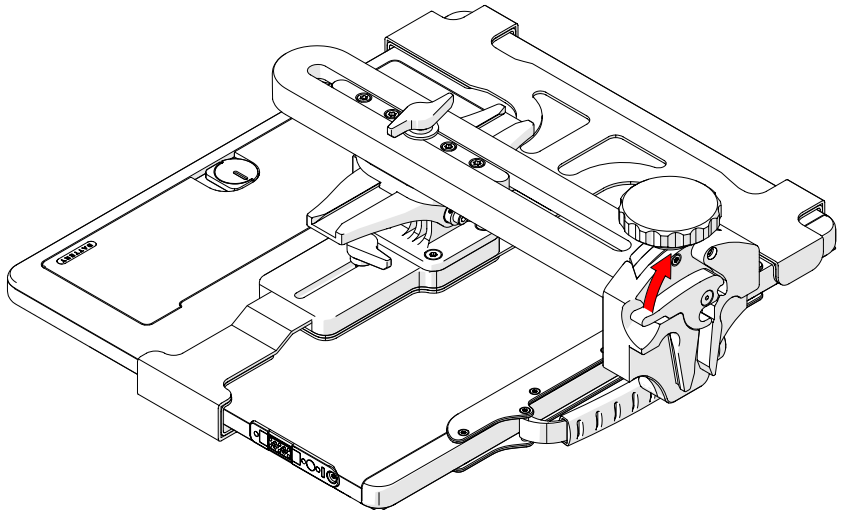

Fig. 50 - Lift latch

1. Ensure that the lever of the detector bracket is lifted (*Fig. 50*).

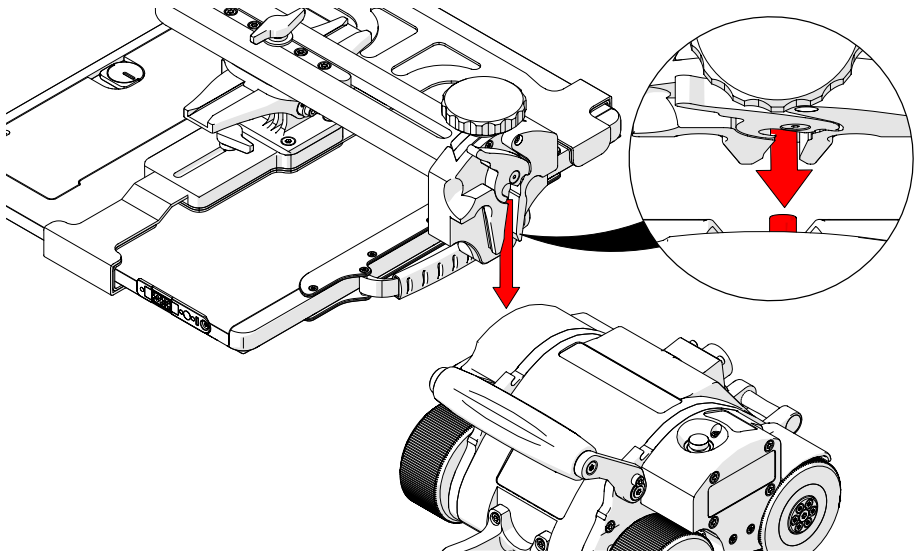

Fig. 51 - Align detector bracket groove with crawler's dowel

2. Align the groove of the detector bracket with the dowel of the **SKOOT•X** crawler (Fig. 51).
3. Lower the detector bracket alongside the crawler until the detector bracket is seated entirely alongside the crawler.

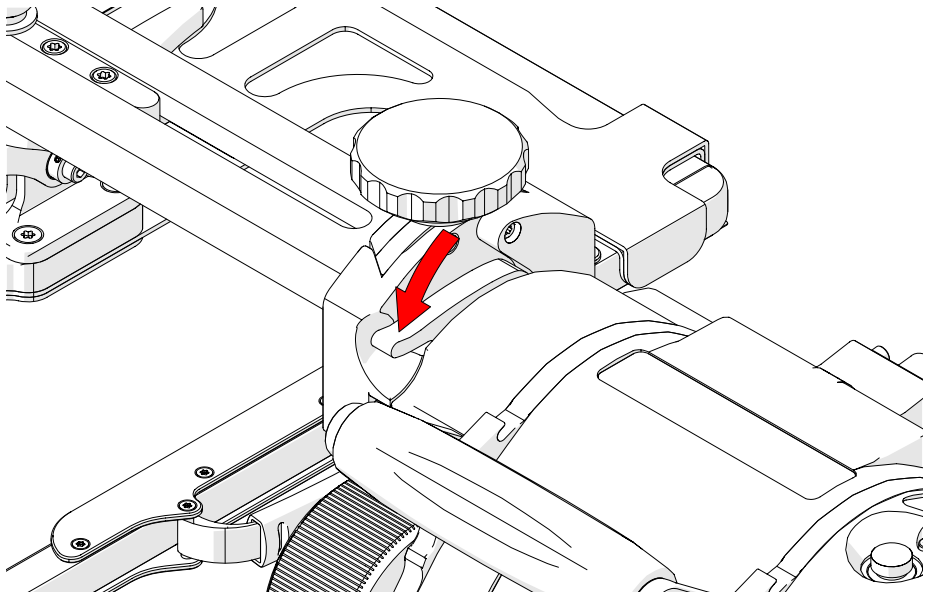

Fig. 52 - Press lever down

4. Press the lever down to lock the detector bracket in place (Fig. 52).

5.5.3. Positioning the Detector

Loosening the wing knob allows for two separate axis of movement.

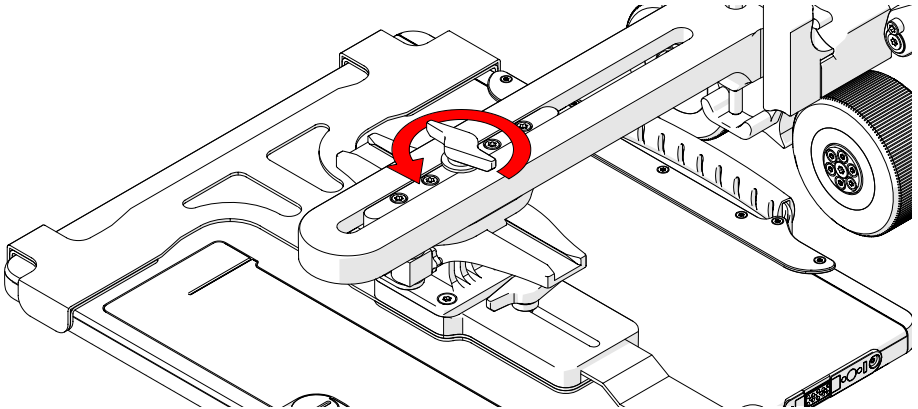

Fig. 53 - Loosen wing knob

1. Loosen the wing knob to allow for movement of the detector (*Fig. 53*).

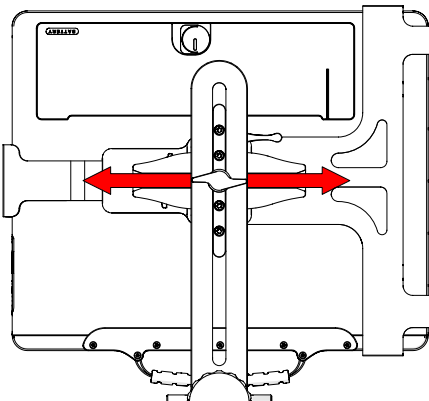

Fig. 54 - Position detector

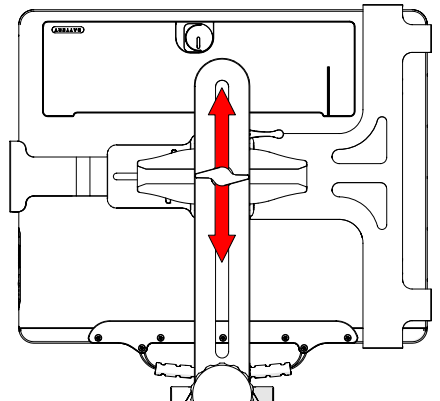

Fig. 55 - Position detector

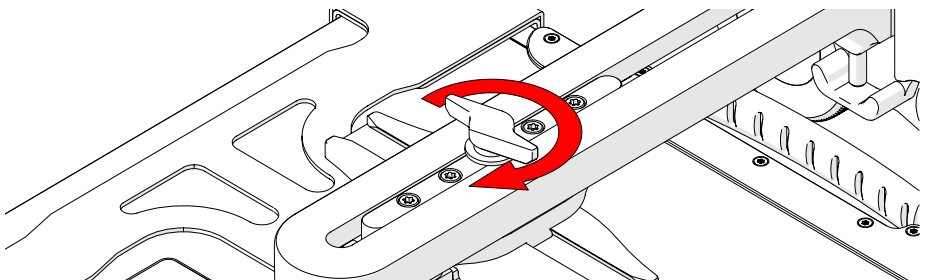

Fig. 56 - Tighten wing knob to lock position

2. Tighten the wing knob to lock the chosen detector position (*Fig. 56*).

5.5.4. Adjusting Detector Height

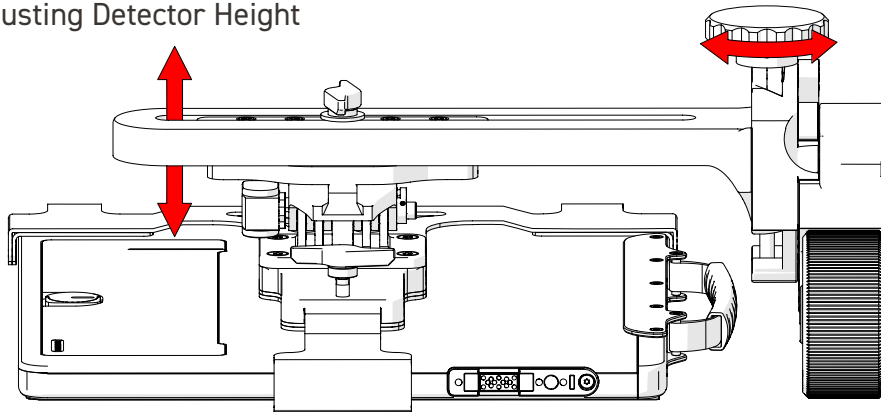

Fig. 57 - Rotating the red knob raises or lowers the detector arm

1. Rotate the red knob on the detector bracket to raise or lower the detector arm (Fig. 57).

5.5.5. Adjusting the Detector Angle

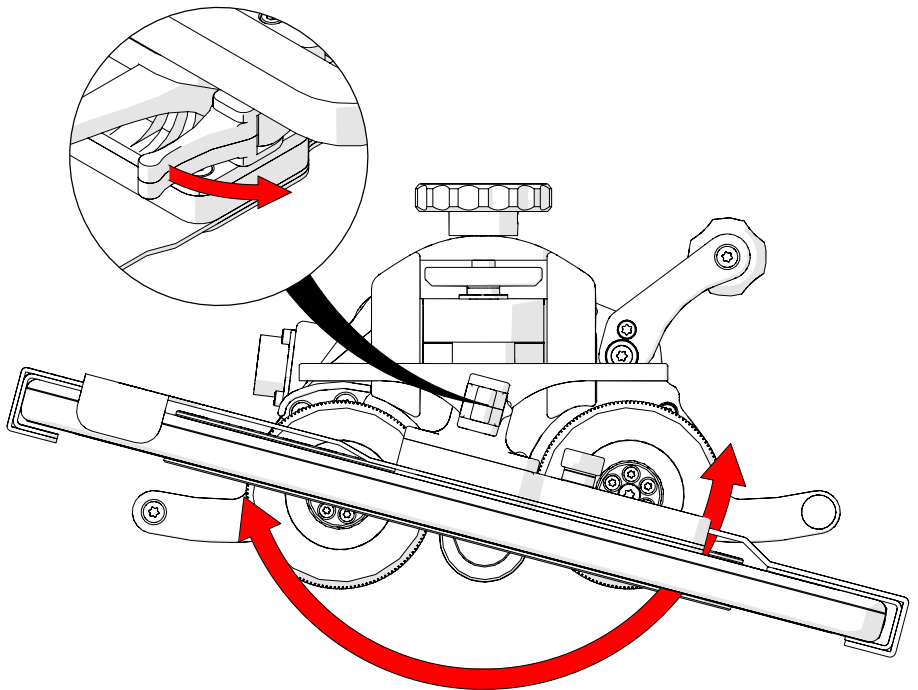

Fig. 58 - Loosen lever and pivot

1. Loosen the lever to pivot the detector as required. Tighten the lever to lock the detector in place (Fig. 58).

5.6. Source Cart

5.6.1. Releasing the Mounting Plate

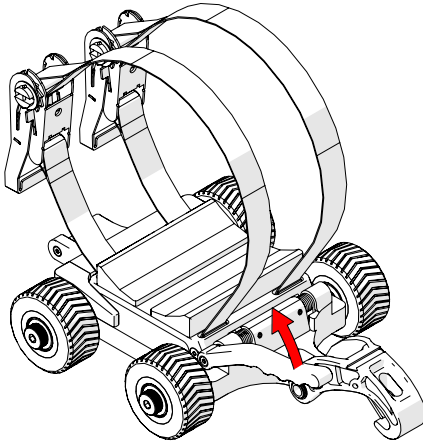

Fig. 59 - Lift lever to release mounting plate

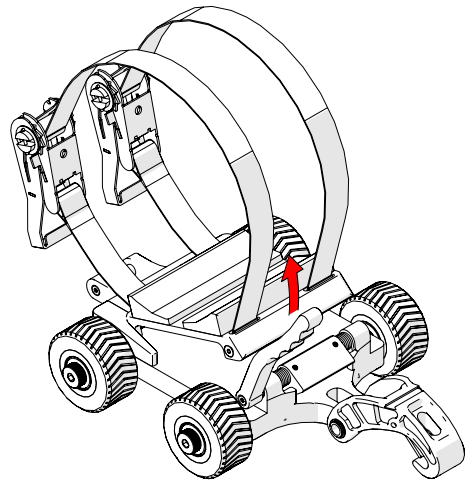

Fig. 60 - Slightly angle mounting plate to remove

1. Lift the lever on the source cart base (Fig. 59) to remove the mounting plate (Fig. 60).

5.6.2. Attaching the Mounting Plate

1. Angle the mounting plate into the source cart base (Fig. 61).
2. Press the mounting plate firmly onto the source cart base. The lever will latch the mounting plate into place.

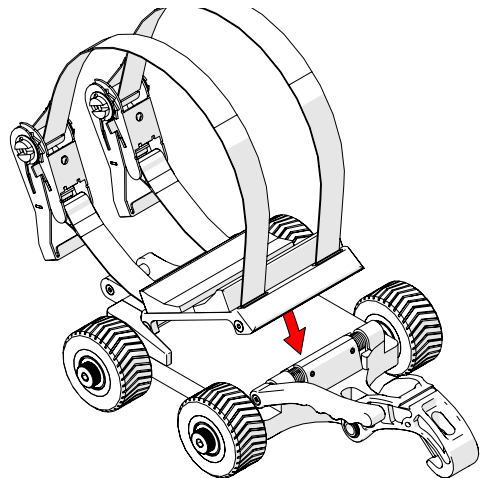

Fig. 61 - Angle the mounting plate and press into place

5.6.3. Mounting Plate

1. Using the ratchet straps provided, attach the source to the mounting plate (Fig. 62).

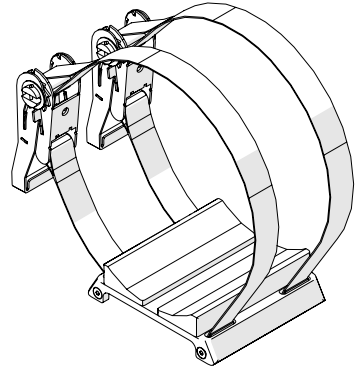

Fig. 62 - Mounting plate with ratchet straps

2. Do not attach the mounting plate to the source cart until the **SKOOT•X** has been properly set up on the inspection surface.

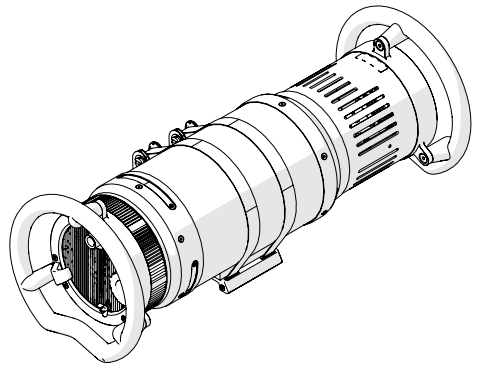

Fig. 63 - Source attached to mounting plate

5.7. Connecting Chain & Dovetail Links

5.7.1. Connecting Chain Links

To connect chain links, see the following steps:

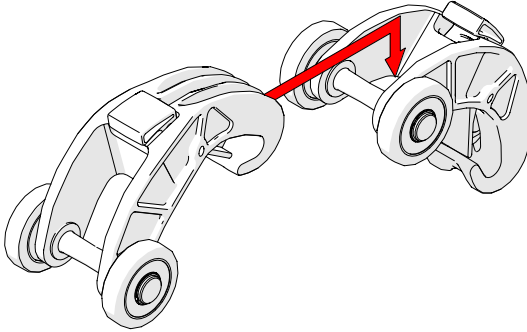

Fig. 64 - Lift the hook over the axle of the link

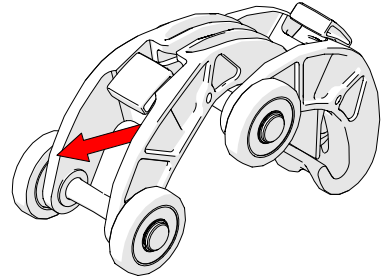

Fig. 65 - Pull the link backwards to secure catch

1. Lift the hook of the chain link over the axle of the chain link that is to be connected (*Fig. 64*).
2. Pull the chain link until you hear a click that ensures the latch has been set (*Fig. 65*).

5.7.2. Disconnecting Chain Links

To disconnect chain links, see the following steps:

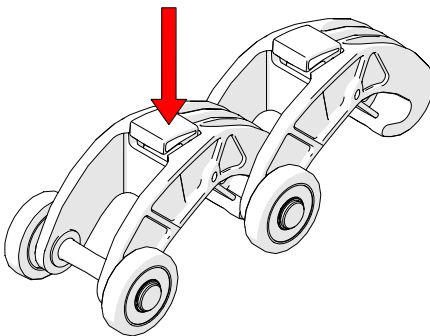

Fig. 66 - Press button

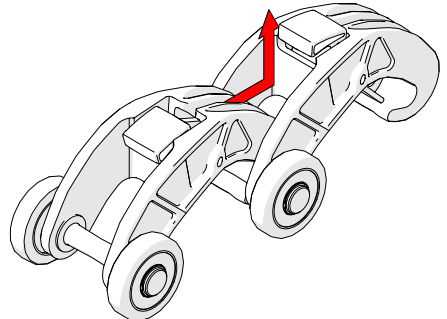

Fig. 67 - Slide link forward and lift

1. Press the button on the top of the chain link (*Fig. 66*).
2. While pressing the button, slide the chain link forward and up, clearing the hook of the chain link from the 2nd link's axle (*Fig. 67*).

5.7.3. Disconnecting the Red Dovetail Links

To disconnect red dovetail links, see the following steps:

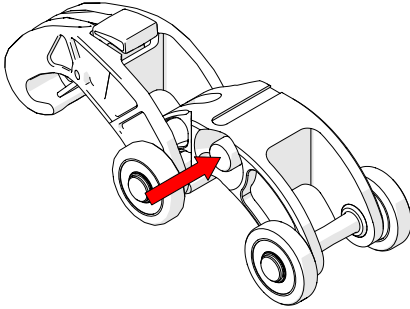

Fig. 68 - Press red button

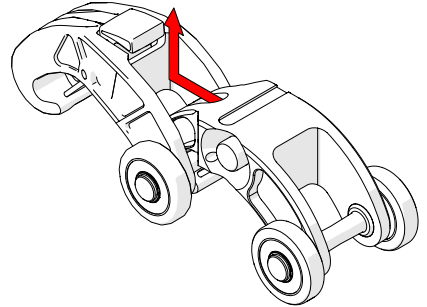

Fig. 69 - Slide link forward and lift

1. Press the button on the side of the red dovetail link (*Fig. 68*).
2. While pressing the red button, slide the red dovetail link forward and up, clearing the hook of the red dovetail link from the 2nd chain link's axle (*Fig. 69*).

5.8. Cable Management

The cable management provides a means of bundling and protecting cables and hoses that connect to the scanner.

5.8.1. Cable Management Dovetail Mount

To attach cable management, follow these steps:

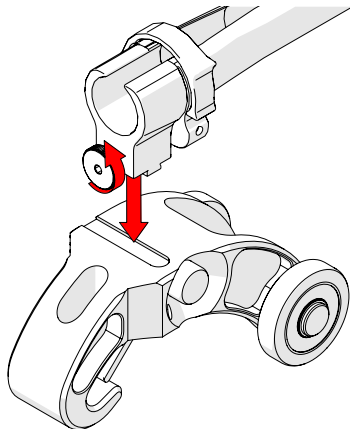

Fig. 70 - Loosen and slide on

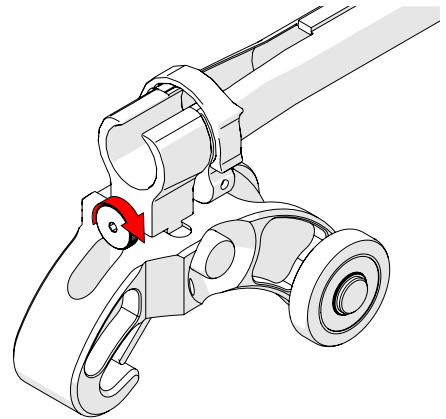

Fig. 71 - Tighten knob

1. Loosen the knob on the cable management dovetail mount. Position the mount onto the red dovetail link (Fig. 70).
2. Once centred on the red dovetail link, tighten the cable management's dovetail mount knob (Fig. 71).

5.8.2. Cable Management Setup

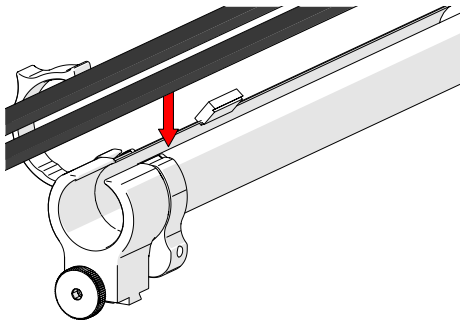

Fig. 72 - Insert cables and hoses

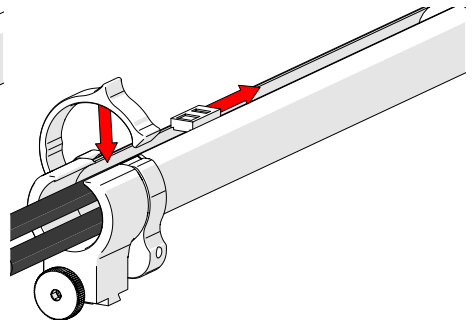

Fig. 73 - Zip to close

1. Open the cable management. Begin at the clamp end and start placing the cabling in the tube (Fig. 72).
2. Close the clamp and zip the tube closed (Fig. 73).

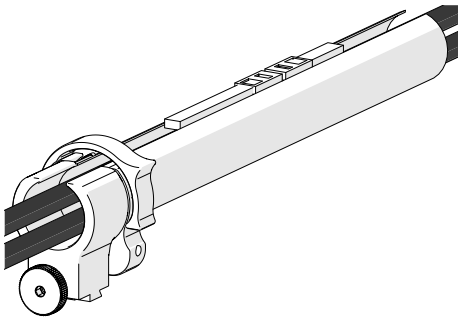

Fig. 74 - Zip opposite end

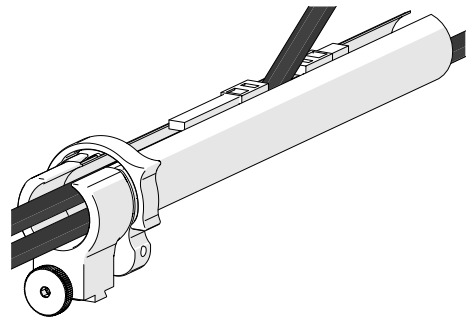

Fig. 75 - Flexible routing

3. Once the cable is placed the entire length of the tube, bring the zipper from the opposite end to meet at any point in the middle (Fig. 74).
4. When necessary, the two zippers may be opened to allow any cables to be routed out of the tube (Fig. 75).

5.8.3. Clamp Setup

If the tube becomes disconnected from the cable management dovetail mount, follow these instructions to re-attach the tube and dovetail mount.

1. Loosen the clamp screw using the supplied 3 mm hex driver (Fig. 76).
2. Slide the clamp around the tube first, and then slide the tube around the outside of the cable management dovetail mount (Fig. 77). Align the zipper opening and the cable management dovetail mount opening.
3. Slide the clamp over the tube and cable management dovetail mount, pinching the tube in between (Fig. 78).
4. Tighten the clamp screw (Fig. 79).

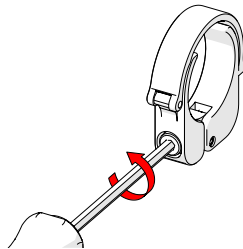

Fig. 76 - Loosen clamp screw

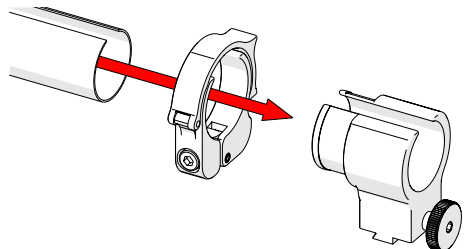

Fig. 77 - Slide tube around mount

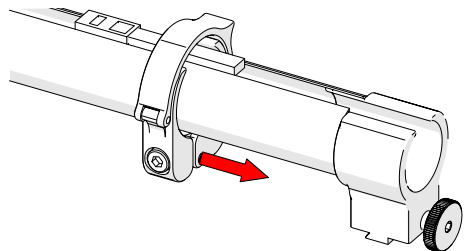

Fig. 78 - Slide clamp onto mount

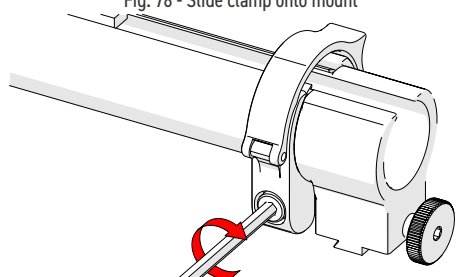

Fig. 79 - Tighten clamp screw

5.9. Backpack

The **SKOOT•X** backpack provides a mounting point for scanning peripherals. The flexible strap securely holds any accessories to the **SKOOT•X** crawler.

5.9.1. Mounting a Backpack

To mount the backpack, follow these steps.

1. Angle the backpack (Fig. 80) towards the notches found on the crawler (located near the base of the handle).

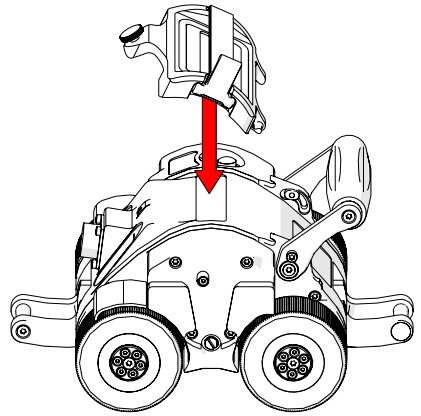

Fig. 80 - Angle backpack

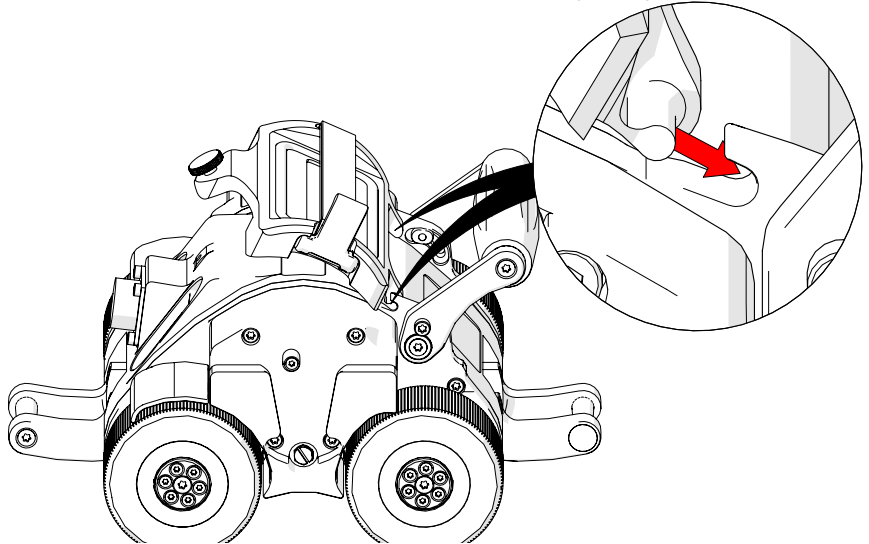

Fig. 81 - Fit backpack into notches

2. Place the front of the backpack into the notches found near the base of the handle (Fig. 81).
3. Lower the backpack and tighten the thumb screw to secure the backpack to the crawler (Fig. 82).

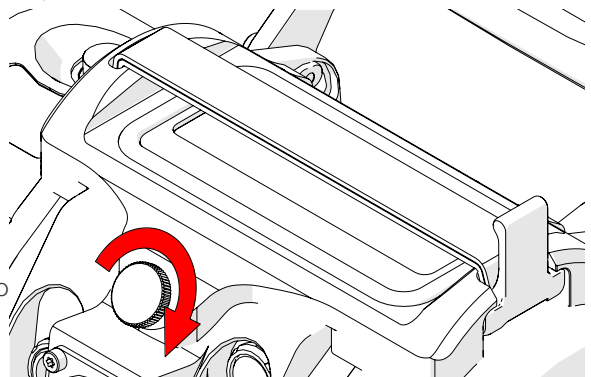

Fig. 82 - Tighten thumb screw

5.9.2. Using the backpack

The flexible strap of the backpack stretches to hold various scanning accessories to a crawler.

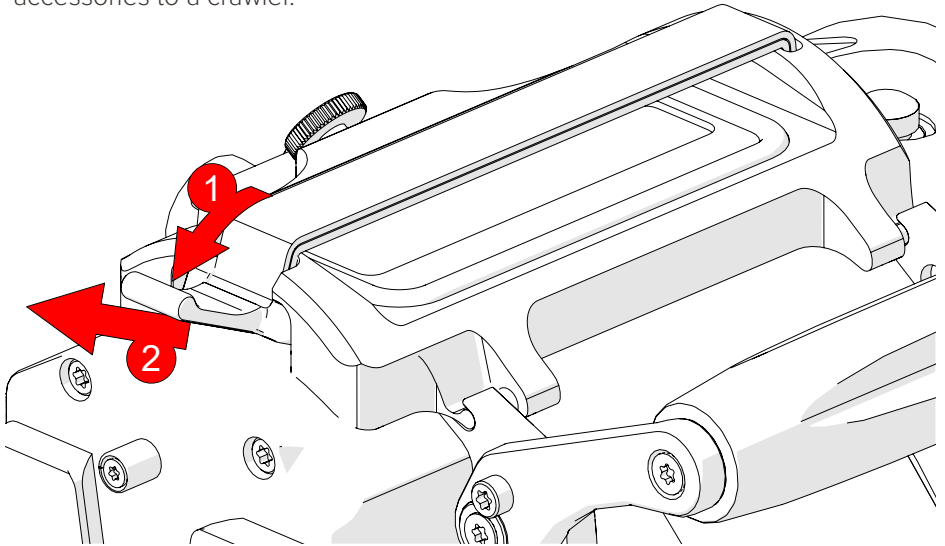

Fig. 83 - Press lever down and pull to release

1. Press the strap's lever down and then pull to release the flexible strap (Fig. 83).

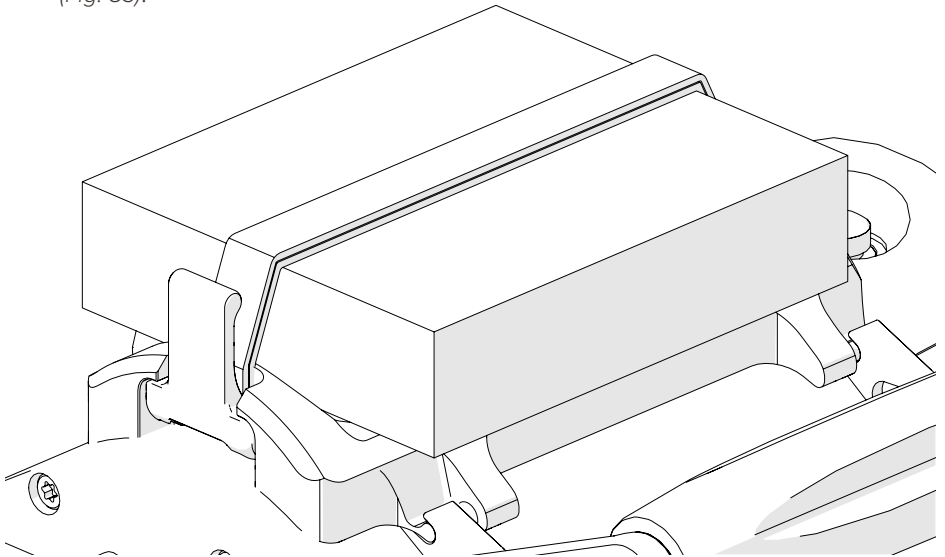

Fig. 84 - Press lever into backpack to lock in place

2. Place the scanning accessory on the backpack. Pull the strap lever across the accessory and fit the lever into place on the backpack (Fig. 84)

OPERATION

6.1. System Startup

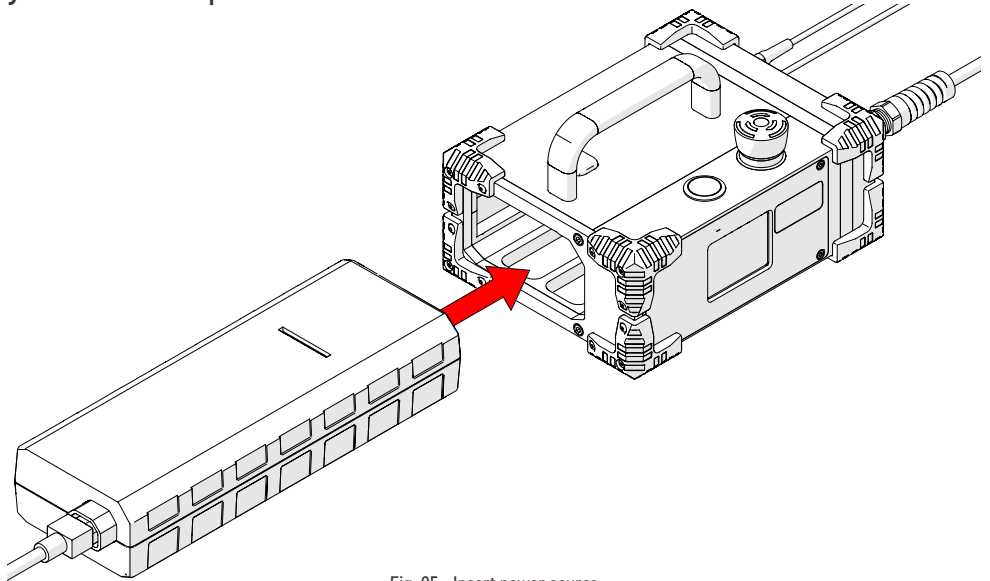

Fig. 85 - Insert power source

To activate the system, follow these steps:

1. Insert the power source (Fig. 85) into the power controller dock.
2. Connect the components (see “Configurations” on page 22).

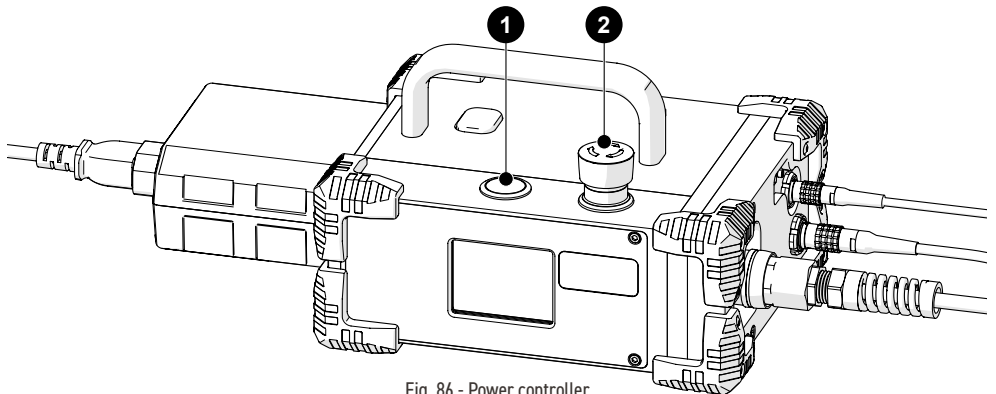

Fig. 86 - Power controller

3. Locate the **2** red emergency stop push-button on the power controller. Rotate this button clockwise to unlatch (Fig. 86).
4. The **1** power button (Fig. 86) on the power controller activates the system.

NOTE: If the crawler is moving due to an external force when power is applied, the system will display a "Please Wait – Motor Moving" message until the movement stops. The crawler must be stationary for system initialization to be performed.

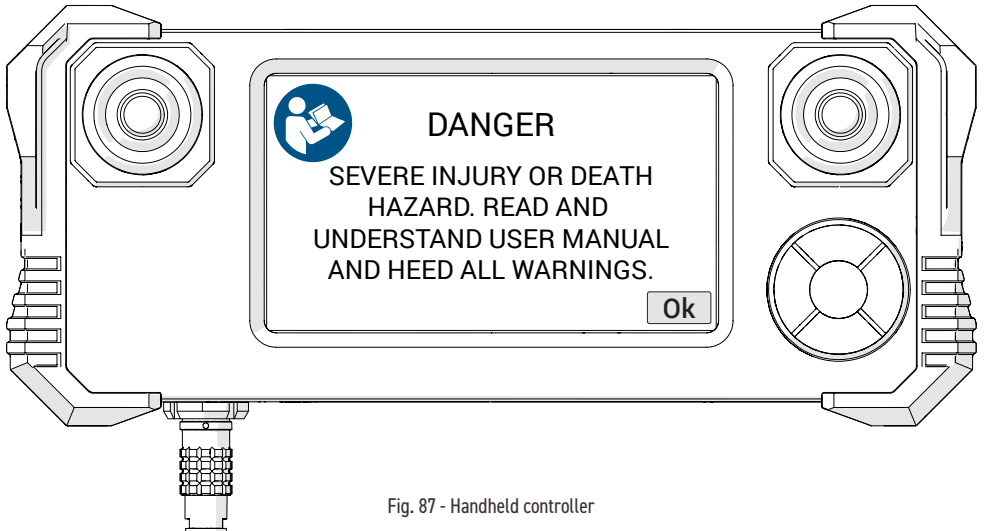

Fig. 87 - Handheld controller

5. A warning message will display on the handheld controller when power has been activated (Fig. 87). Once the dangers of using the **SKOOT•X** are recognized and understood by reading this user manual, touch **Ok** to acknowledge the warning.

Once the system is initialized, the **Mode Select** screen will appear (see "Mode Select Screen" on page 53). The system is now ready for operation.

6.2. Placement of Crawler on Inspection Surface

6.2.1. Chain System



CAUTION! Do NOT handle crawler using the umbilical cable. Use the provided handle.

1. Determine the diameter of the pipe or tube to be scanned. Included in the **SKOOT•X** kit and in this manual are setup charts which indicate the number of links required based on the diameter of the pipe or tubing. Refer to the appropriate chart based on the number of probes to be used when scanning (Fig. 88).

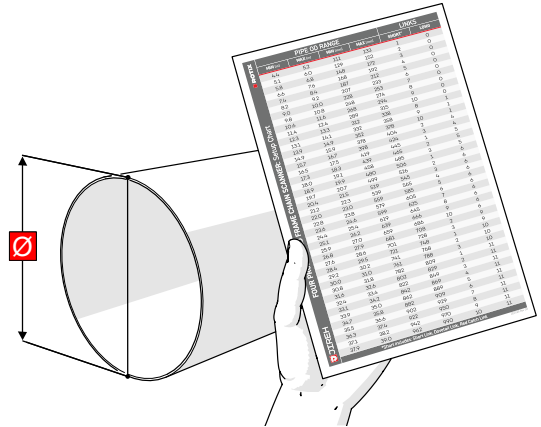

Fig. 88 - Refer to setup chart

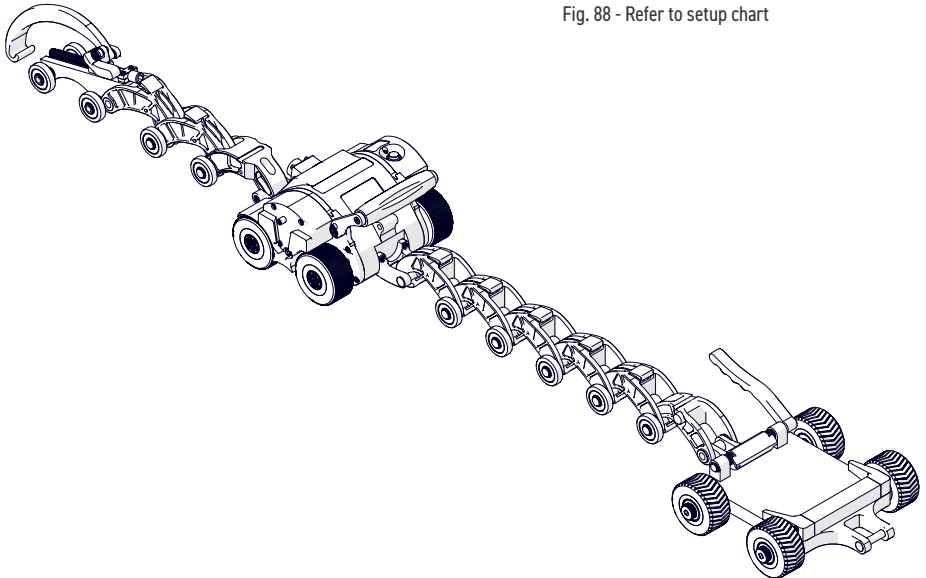

Fig. 89 - Assemble configuration

2. On a flat surface, connect the appropriate number of links as indicated on the setup chart (see "SKOOT•X Chain Configuration Setup Chart" on page 89).

TIP: The following example is configured for a 40.6 cm (16 in) pipe diameter.

3. Remove the mounting plate from the source cart base (see “Source Cart” on page 18).
4. Attach the umbilical to the crawler (see “Umbilical” on page 26).
5. Attach the cable management and route cabling (see “Cable Management” on page 38).
6. Activate the system (see “System Startup” on page 42).
7. Do not attach the detector bracket or source to the configuration until the setup of the system is complete and mounted securely to the inspection surface.
8. Drape the configured system around the pipe/tube to be inspected (Fig. 90).

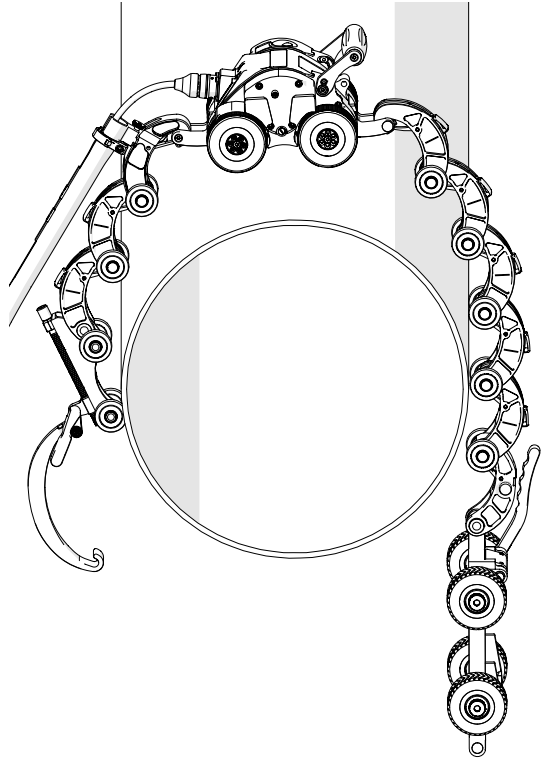

Fig. 90 - Place system on pipe/tube

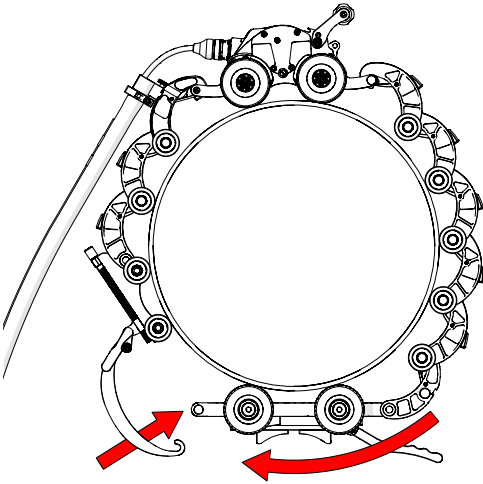

Fig. 91 - Hook buckle to chain link

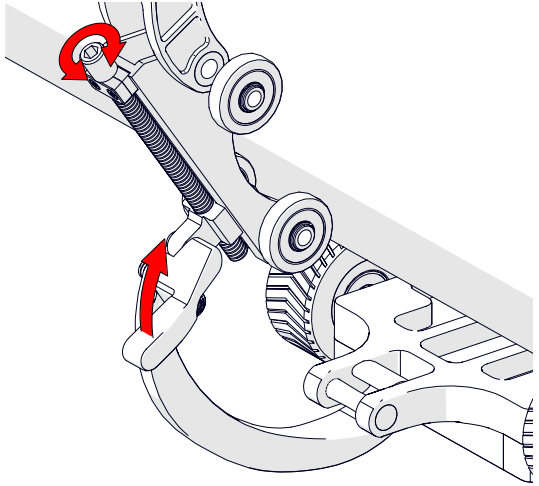

Fig. 92 - Adjust buckle as required

9. Bring the buckle arm towards the chain link. Hook the buckle's arm to the middle axle of the chain link (Fig. 91).
10. The buckle adjustment knob may have to be tightened or loosened to allow the buckle arm to reach/hook the chain link's axle (Fig. 92).
11. The buckle adjustment knob may have to be tightened or loosened to achieve the required chain tightness (Fig. 92).
12. Push the buckle lever down, locking the chain system in place (Fig. 93).

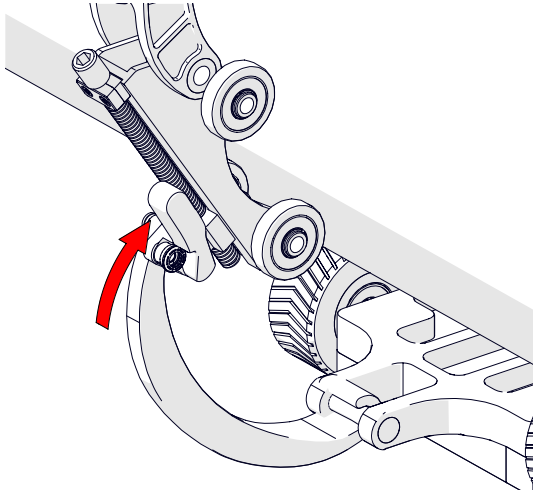

Fig. 93 - Press down to tighten chain system

13. Drive the system forward or in reverse to bring the source cart base to the three o'clock or 9 o'clock position (see "Jog Mode" on page 54). The red lever of the source cart base should ideally be angled upwards (Fig. 94).

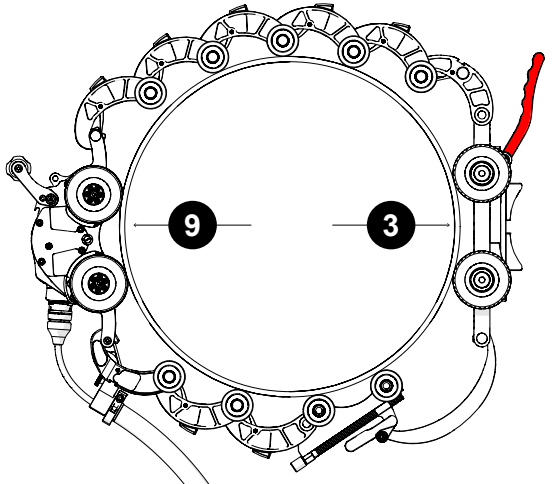

Fig. 94 - Position source cart at 3 or 9 o'clock with lever pointing up

14. Attach the source (Fig. 95) to the mounting plate (see "Mounting Plate" on page 35).
15. Angle the mounting plate (Fig. 95) and press the mounting plate onto the source cart base (see "Attaching the Mounting Plate" on page 34).

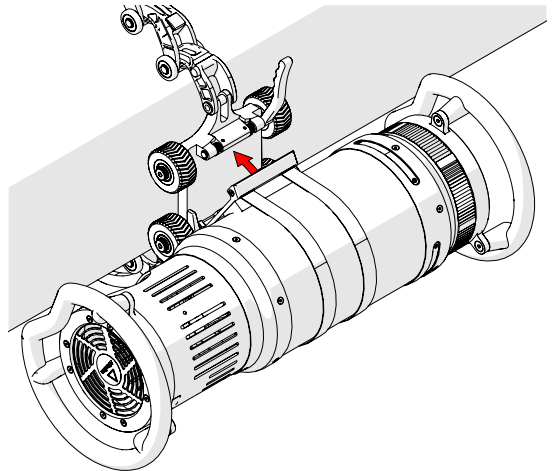

Fig. 95 - Mount source to source cart

16. Attach the detector to the detector bracket (see "Attaching Detector to the Detector Bracket" on page 29).
17. Mount the detector bracket (Fig. 96) to the crawler (see "Mounting Detector Bracket to Crawler" on page 30).
18. Angle and align the detector bracket as required (see "Positioning the Detector" on page 32).

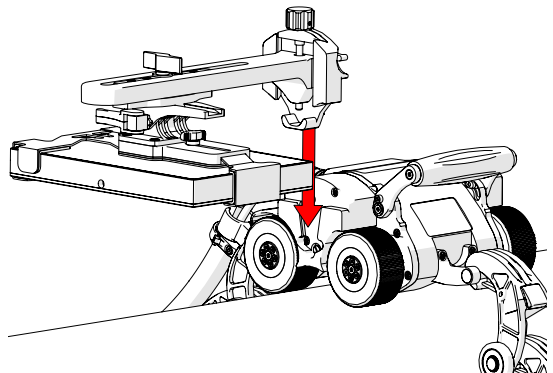

Fig. 96 - Mount detector bracket to the crawler

19. Use the handheld controller to drive the crawler to the top dead centre of the pipe before beginning the 1 Axis Scan Setup (see "1 Axis Scan Mode" on page 56).

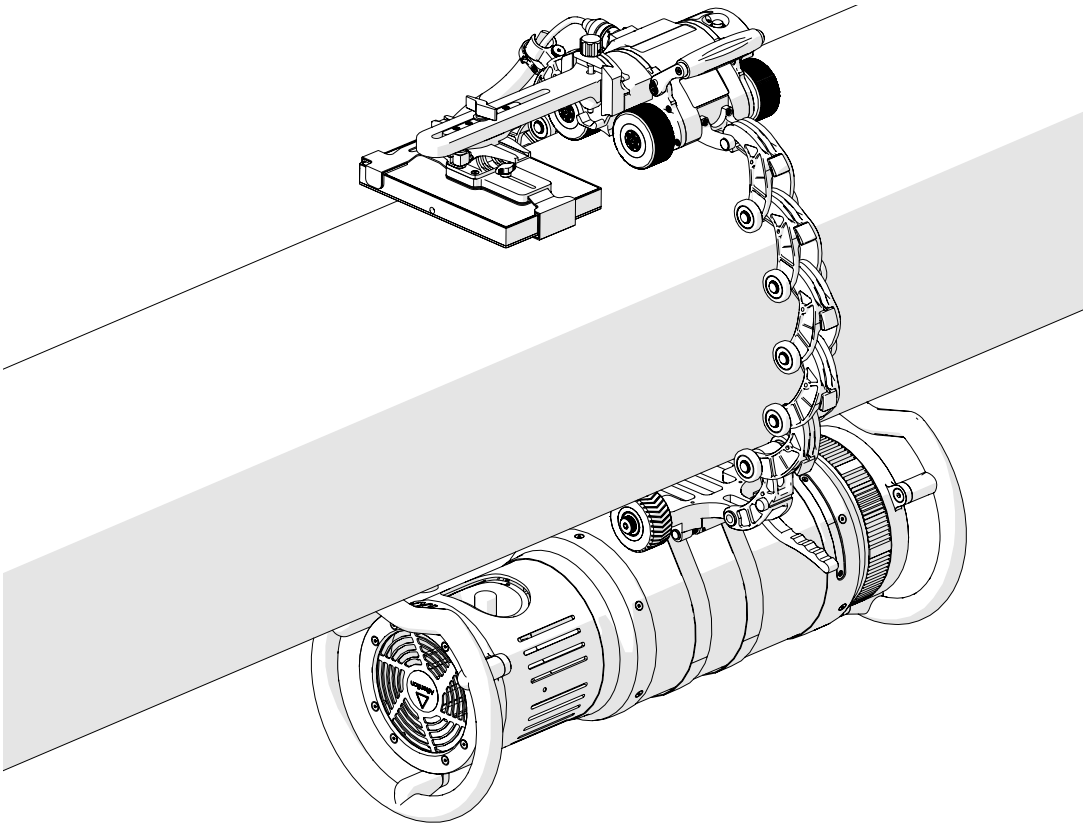

Fig. 97 - Prepared SK00T-X chain system

6.2.2. Magnetic System



CAUTION! Do **NOT** handle crawler using the umbilical cable. Use the provided handle.



CAUTION! To place the crawler on the inspection surface, use the scanner installation/removal mat (*Fig. 16*) as a spacer between the wheels and the surface on which the crawler is to drive. This is necessary to protect the electronic components within the crawler from damaging shock, should the crawler be slammed directly onto the surface.



WARNING! MAGNETIC MATERIAL. The wheels of the crawler produce an extremely strong magnetic field which may cause failure or permanent damage to items such as watches, memory devices, CRT monitors, medical devices or other electronics.

Tools, magnets and metal objects can cut, pinch or entrap hands and fingers. **HANDLE WITH CARE.**

People with pacemakers or ICD's must stay at least 25 cm (10 in) away.

WARNING! MAGNETIC MATERIAL. The installation/removal mat contains magnetic material. Those with pacemakers or ICD's must stay at least 10 cm (4 in) away.

1. Attach the umbilical to the crawler (see “Umbilical” on page 26).

6.2.2.2 Scanner Installation/Removal Mat Use

To place the crawler on the inspection surface, follow these steps:

NOTE: The manufacturer recommends two persons install the crawler on an inspection surface. One person to lower the crawler to the scan surface, and one person to operate the crawler via the handheld controller.

1. Ensure crawler preparation is complete (see “Preparation for Use” on page 21) and system startup has been performed (see “System Startup” on page 42).

2. Set the crawler to Jog Mode (see “Jog Mode” on page 54).

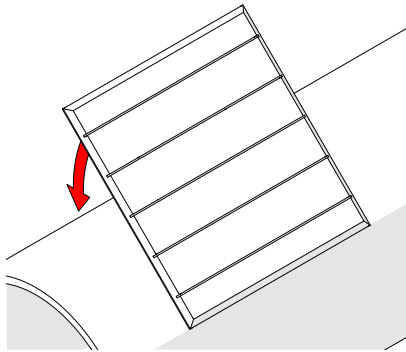

Fig. 98 - Place installation/removal mat

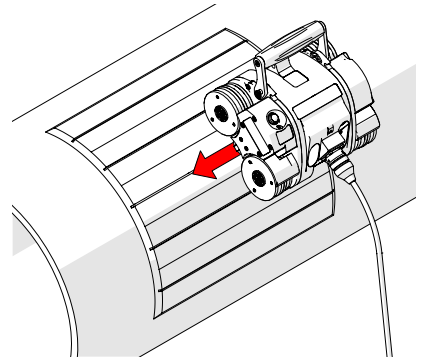

Fig. 99 - Place installation/removal mat

3. Place the installation/removal mat on the inspection surface (Fig. 98).
4. Place and hold the crawler on the installation/removal mat (Fig. 99).

NOTE: Do NOT release the crawler when placed on the installation/removal mat.

5. Ensure all four wheels of the crawler are held firmly against the installation/removal mat. While holding the crawler, use **Jog Mode** (see “Jog Mode” on page 54) to carefully drive the crawler (Fig. 100) off the installation/removal mat and onto the inspection surface (Fig. 101).

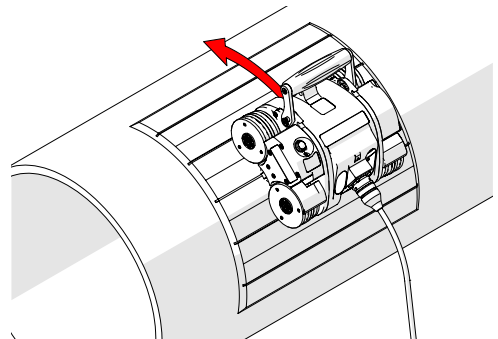

Fig. 100 - Drive crawler off the mat

TIP: Avoid the crawler slamming to the inspection surface. This can occur when all four wheels are not in contact with the installation/removal mat while the crawler is driven onto the inspection surface.

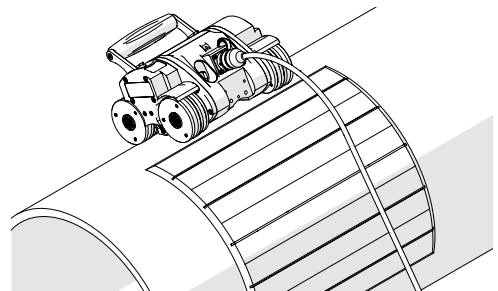

Fig. 101 - Magnetized to surface

6. Remove the installation/removal mat from the inspection surface.

TIP: Circumstance may arise when only one person is available for placement of the crawler on an inspection surface. With the system power off, it is possible to place the crawler on the inspection/removal mat and manually push the crawler off the mat and onto the inspection surface.

6.2.2.3 Detector Setup

1. Attach the detector to the detector bracket (see “Attaching Detector to the Detector Bracket” on page 29).
2. Mount the detector bracket (Fig. 102) to the crawler (see “Mounting Detector Bracket to Crawler” on page 30).
3. Angle and align the detector bracket as required (see “Positioning the Detector” on page 32).

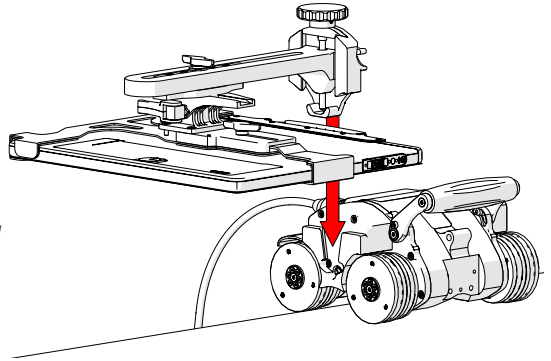

Fig. 102 - Mount detector bracket to the magnetic crawler

6.2.2.4 Crawler Position

1. Use the handheld controller to drive the crawler to the top dead centre of the pipe before beginning the 1 Axis Scan Setup (see “1 Axis Scan Mode” on page 56).

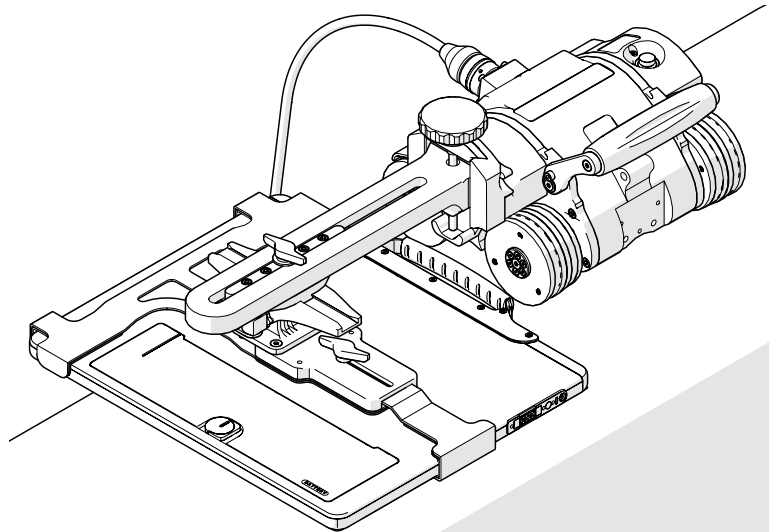

Fig. 103 - Prepared SK00T-X magnetic system

6.3. Operation

6.3.1. Handheld Controller Layout

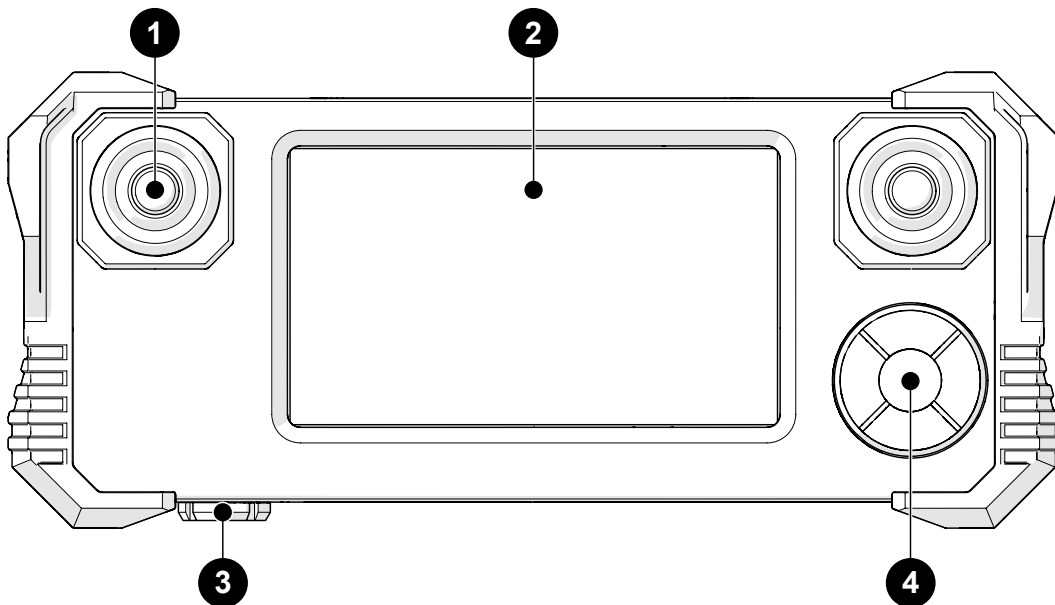

Fig. 104 - Handheld Controller

1	Fwd/Rev joystick	(see “Joysticks” on page 53)
2	Touchscreen	(see “Touchscreen” on page 52)
3	Controller cable connector	Connection point for the auxiliary cable.
4	D-pad	A means of navigating the on-screen menus of the handheld controller.

6.3.1.1 Touchscreen

The **2** handheld controller’s touchscreen is the primary operator interface for the system (Fig. 104).

6.3.1.2 D-pad

The **4** D-pad provides a redundant system control that may be utilized as an alternative to the touchscreen. A red highlight around a button indicates the D-pad selection. Pressing the outer buttons of the D-pad selects different buttons on-screen. Press the centre button of the D-pad to choose the button currently selected.

6.3.1.3 Joysticks

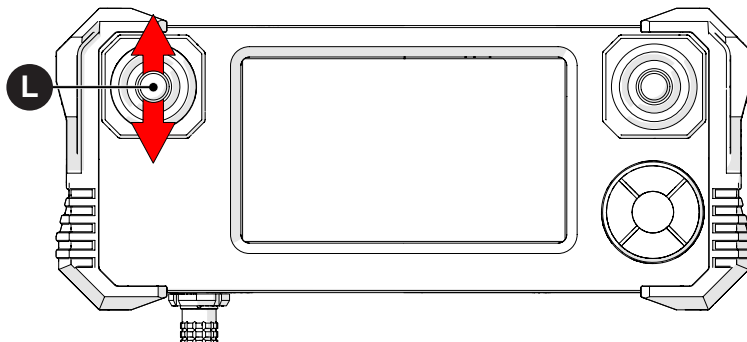

Fig. 105 - Handheld controller joysticks

The joysticks control system motion (Fig. 105). The **L** left joystick controls the crawler's forward/reverse movement.

6.3.2. Mode Select Screen

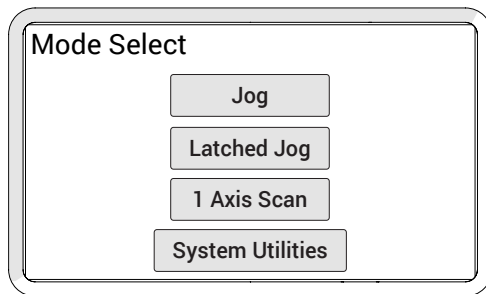

Fig. 106 - Mode select

The **Mode Select** screen offers four modes of operation for the system:

Jog Mode	(see "Jog Mode" on page 54)
Latched Jog Mode	(see "Latched Jog Mode" on page 55)
1 Axis Scan Mode	(see "1 Axis Scan Mode" on page 56)
System Utilities	(see "System Utilities Screen" on page 59)

6.3.3. Jog Mode

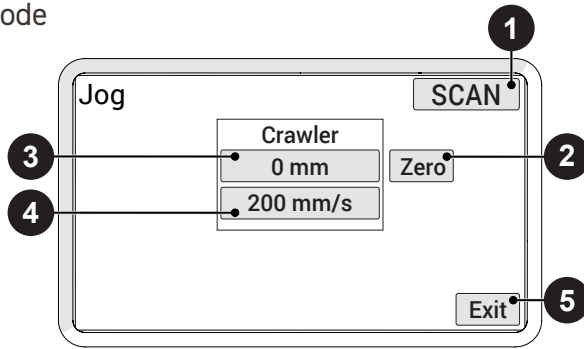

Fig. 107 - Button identification

Jog mode manually controls the system movement using the joysticks.

- 1** Scan/Rapid Button
(Fig. 107)

Used to quickly switch between crawler speeds. The speed in either mode can be manually set to the user's preference.

TIP: Fine adjustments to speed can be made in the User Settings (see "User Settings Screen" on page 60).

- 2** Zero Button

Sets the current position to zero for all modules.

- 3** Module Position Button(s)

Displays the current position of the crawler. Press to set the position to any value using the **Edit** screen. When a module position is modified, the position will be modified for all other system modes.

NOTE: This function only zeroes the number displayed on the **SKOOT•X** handheld controller. It does not zero the position used in the data acquisition instrument.

- 4** Module Rate Button(s)

Displays the current maximum rate for the selected speed mode. Press to set the maximum rate using the **Edit** screen. The movement commanded by the joysticks will be limited to the indicated rate. When a rate is modified, the rate will be modified for all other system modes.

- 5** Exit Button

Exits the **Jog Mode** screen.

6.3.4. Latched Jog Mode

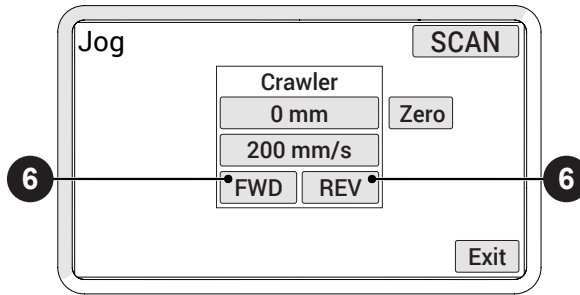

Fig. 108 - Latched jog mode

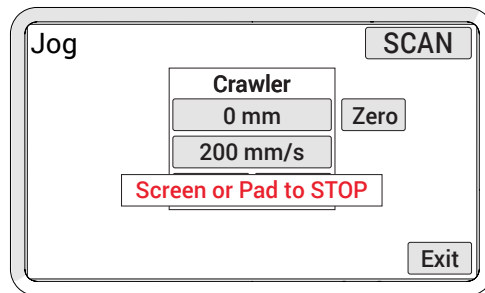

Fig. 109 - Latched jog stop screen

Identical to standard jog mode, latched jog mode adds forward or reverse crawler movement at the selected scan rate. This eliminates the need to manually hold the left joystick (see “Jog Mode” on page 54).

6 FWD & REV Buttons:

The **FWD** and **REV** buttons are located in the crawler tab. Press the **FWD** or **REV** button to drive the crawler at the current maximum scan rate. Touching the handheld controller screen or pressing the D-pad stops the crawler movement.

NOTE: The **FWD** & **REV** Buttons will not be present in rapid mode.

6.3.5. 1 Axis Scan Mode

6.3.5.1 1 Axis Scan Setup Screen

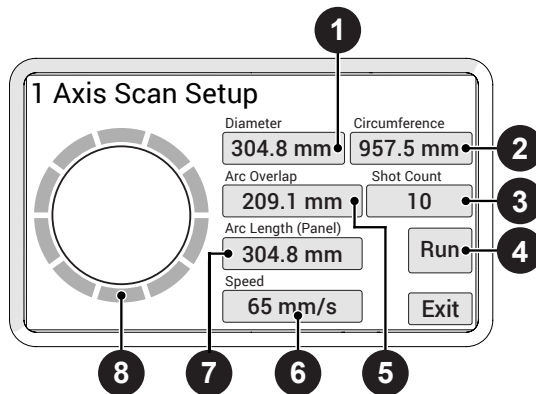

Fig. 110 - 1 Axis scan mode

1 Axis Scan Setup Screen permits the user to setup the parameters of the inspection.

NOTE: Use the handheld controller to drive the crawler to the top dead centre of the pipe before beginning the 1 Axis Scan Setup.

- | | |
|------------------------|--|
| 1 Diameter | The diameter of the pipe can be manually entered. Alternatively, the diameter is automatically calculated when the circumference is entered. |
| 2 Circumference | The circumference of the pipe can be manually entered. Alternatively, the circumference is automatically calculated when the diameter is entered. |
| 3 Shot count | The number of stops the crawler will make around the pipe. Shot count will automatically calculate the arc overlap. |
| 4 Run | Opens 1 Axis Scan Screen where user can start operation (see "1 Axis Scan Screen" on page 57). |
| 5 Arc Overlap | Manually enter the amount of shot overlap desired (rounded to the nearest shot count). Alternatively the overlap is automatically calculated when the shot count is entered. |
| 6 Speed | The speed when the crawler is travelling between shot locations. |

- 7** Arc Length (Detector) The approximate dimension of the detector. This measurement is defined in the scan direction.
- 8** Visual A visual representation of the shot locations.

TIP: Toggle between metric and imperial measurement in the User Settings.

6.3.5.2 1 Axis Scan Screen

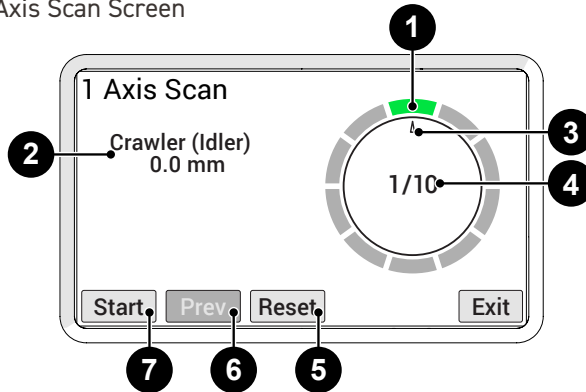

Fig. 111 - 1 Axis scan screen

The **1 Axis Scan** screen is for driving the crawler around a pipe, stopping at the programmed intervals.

- 1** Active Shot Location The green highlight visually indicates the current shot location.
- 2** Crawler (*Idler*) The current position of the crawler according to the idler encoder.
- 3** Crawler location Graphical representation of the crawler location.
- 4** Shot Count Indicates the number of shot locations passed and remaining.
- 5** Reset Return the scanner to the starting location.
- 6** Prev Return crawler to previous shot location.
- 7** Start button Press to begin the programmed sequence. When start is pressed the first time, the scanner will travel to the next shot location and pause. Pressing the start button again will travel to the next shot location.

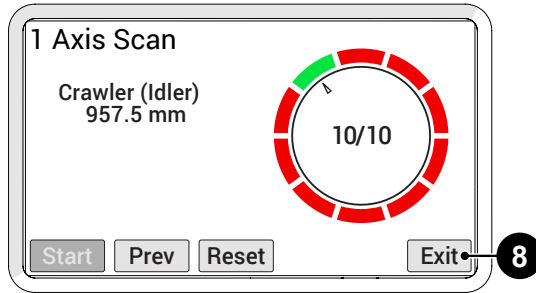

Fig. 112 - 1 Axis scan screen

8 Exit button

Pressing **Exit** stops all scanning motion. When the scanner is not in the initial position, a warning appears (*Fig. 113*). The warning alerts that the initial position of the scanner will be changed to the current position.

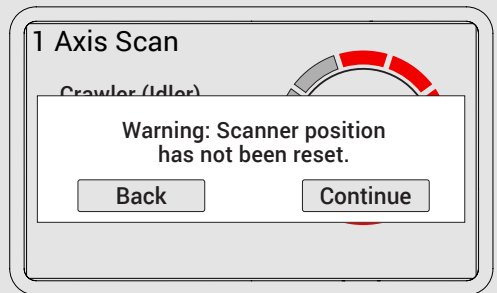

Fig. 113 - Exit warning

Press **Back** to return to the **1 Axis Scan** screen to reset the scanner and maintain the original initial position. Press **Continue** to exit to the **1 Axis Scan Setup** screen.

6.3.6. System Utilities Screen

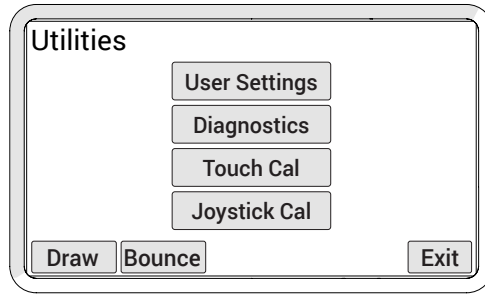

Fig. 114 - Utilities screen

The **Utilities** screen provides access to the setup, diagnostics and user preference settings.

User Settings Button (Fig. 114)	Access the User Settings screen allowing for various user preferences to be adjusted.
Diagnostics Button	Enters the Diagnostic screens to monitor system components and function.
Touch Cal Button	Used to initiate the Touch Calibration screen.
Joystick Cal Button	Used to enter the Joystick Calibration screen.
Draw Button	Enters mode used to test the touch screen accuracy and response.

6.3.6.1 User Settings Screen

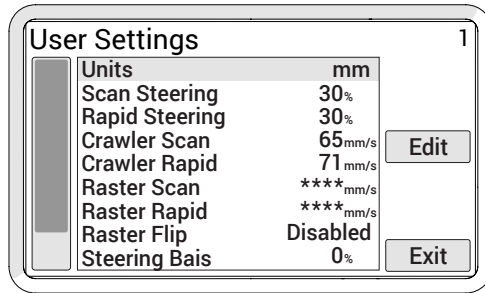

Fig. 115 - User settings screen

Allows users to customize the system to their preferences.

Use the touch screen or D-pad to select different settings.

Press **Edit** to enter the **Edit** screen to apply changes to the selected setting.

Title	Description	Valid Range	Default
Units	Change the measurement units for display and user entry. When set to 0, units measure in inches. When set to 1, units measure in millimetres.	inches or mm	mm
Display Brightness	Sets the brightness of the display.	0-100	100%
Scan by Idler Wheel	Enables the idler encoder for crawler positioning in 1 axis scan mode. In automatic scan modes, if an idler encoder is available, enabling it will reduce the actual crawler position error as the idler encoder is not affected by drive wheel slippage on the surface.	Disabled or Enabled	Enabled
Scan Shortest Move	Used to eliminate small correction moves in 1 axis scan mode.	Min 0.254 mm (0.01 in) Max 59.94 mm (2.36 in)	6.35 mm (0.25 in)

6.3.6.2 Diagnostics Screens

Several diagnostic screens allow various system functions to be monitored. Navigate to different diagnostic screens using the **PREV** and **NEXT** buttons. The **Exit** button returns to the **System Utilities** screen.

NOTE: *The diagnostic information requires an in-depth understanding of the underlying technologies and programming in the system. Not all functions and information is explained in this manual.*

6.3.6.2.1. Detected Modules

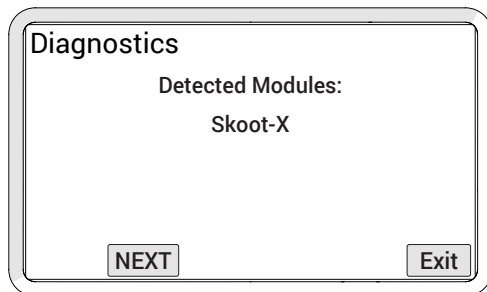

Fig. 116 - Detected modules screen

This screen indicates the system software version and displays which modules were detected when the system was activated.

6.3.6.2.2. System 1

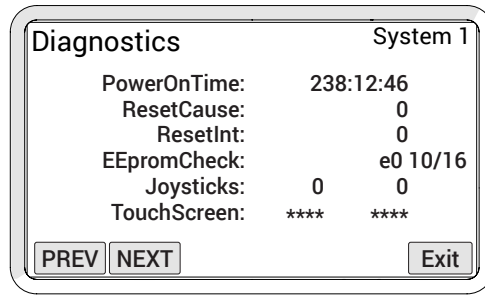

Fig. 117 - Diagnostic screen

System 1 diagnostic screen displays general system function information.

PowerOnTime	The total accumulative time the handheld controller has been powered.
Joysticks	Indicates the raw position reading from the joysticks.
TouchScreen	Indicates the raw position reading from the last touchscreen contact.

6.3.6.2.3. System 2

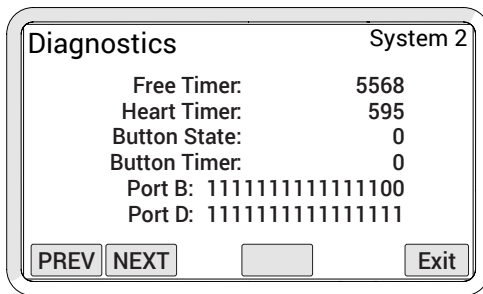

Fig. 118 - Diagnostic screen

Additional general system function information is displayed within the **System 2** screen. An empty button is provided to allow testing of the D-pad.

Free Timer	Value from a free running system timer. If this timer is static, an internal controller issue is present.
Button State	Shows the state of the pushbuttons in the D-pad.
Button Timer	Shows the timer associated with the D-pad.

6.3.6.2.4. System 3

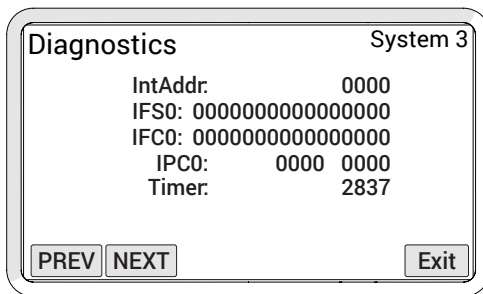

Fig. 119 - Diagnostic screen

The **System 3 Diagnostic** screen displays additional system information. The information provided does not typically assist the user.

6.3.6.2.5. Skoot-X

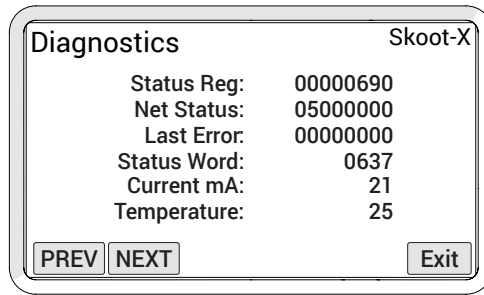

Fig. 120 - Diagnostic screen

The **Skoot-X diagnostic** screen provides information regarding the status of the crawler. A separate screen is available for each module detected upon system startup.

Current MA

Displays the output of the crawler to the motor. The current (mA) displayed is directly proportional to the motor's output torque. This reading can be used to check if the control system is responding to forces on the module's motor.

Temperature

Internal temperature reading of the crawler in degrees Celsius.

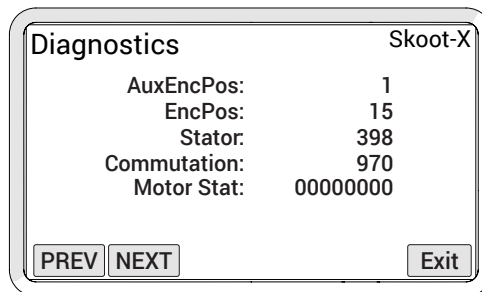

Fig. 121 - Diagnostic screen

AuxEncPos	Displays the position of the auxiliary encoder in counts when connected to the module. When the auxiliary encoder is moved, this number will change. When the encoder is moved from its current position and then back to that exact same position, this number will also return to its original position.
EncPos	The position of the modules motor encoder in counts.

6.3.6.3 Touch Calibration Screen



Fig. 122 - Touch calibration screen

This option allows calibration of the touch screen. Typically, this should not be necessary.

Touch the screen as the markers appear in the four corners of the screen.

TIP: *It is recommended that the markers be touched with a small object to enhance the touch position accuracy during calibration.*

The new calibration is stored immediately when the fourth marker is pressed. The calibration utility exits and return to the **System Utilities** screen. To abort the calibration, the system power may be turned off before the last marker is pressed.

6.3.6.4 Joystick Calibration Screen

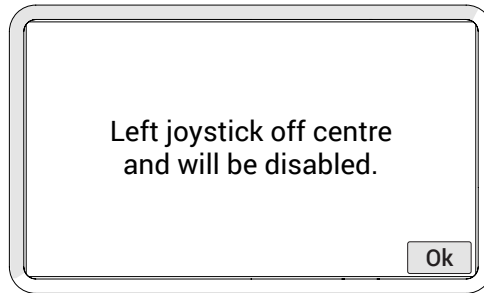

Fig. 123 - Joystick error

Typically joystick calibration is only necessary when a joystick off-centre error is detected upon startup (Fig. 123). Calibration may also be used when a joystick function does not appear to be properly centred.

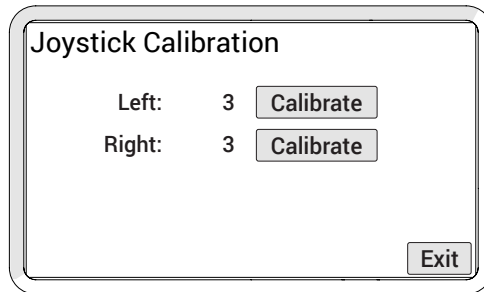

Fig. 124 - Joystick calibration screen

Current readings of the joysticks are displayed on the **Joystick Calibration** screen (Fig. 124). When the numbers are not near zero, press the **Calibrate** button to recalibrate to 0. The new calibration is stored when the **Exit** button is pressed.

6.3.6.5 Draw



Fig. 125 - Draw utility

The draw utility may be used to test the function of the touchscreen. Exit the utility by pressing the D-pad.

6.3.7. High Internal Temperature Screen

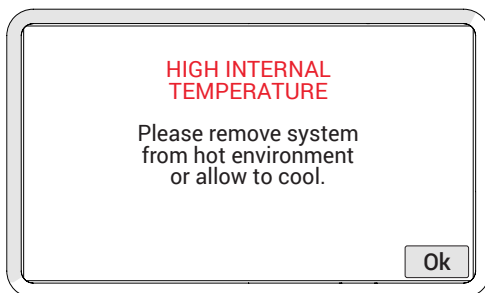

Fig. 126 - High internal temperature screen

When the system approaches its maximum operating temperature, the high internal temperature screen will display. When this alert screen is displayed, all motor and system functions will cease.

Press **OK** to reactivate the system to remove **SKOOT•X** from the scan surface.

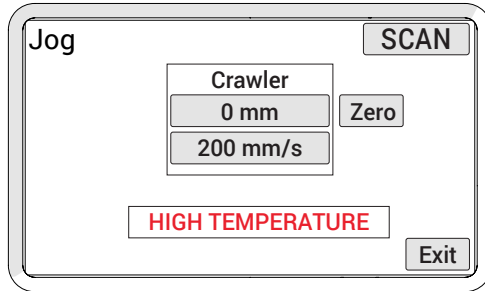

Fig. 127 - High internal temperature screen

Should the user choose to continue operating the crawler, the HIGH TEMPERATURE warning will continue to display until the temperature falls below the set temperature limit.

MAINTENANCE

7.1. Safety Precautions Before Maintenance



WARNING! ELECTRICAL SHOCK HAZARD. Disconnect the power controller when servicing the equipment. The power controller is powered even when the E-Stop push-button is latched in the off position.



WARNING! MAGNETIC MATERIAL. The wheels of the crawler produce an extremely strong magnetic field which may cause failure or permanent damage to items such as watches, memory devices, CRT monitors, medical devices or other electronics.

Tools, magnets and metal objects can cut, pinch or entrap hands and fingers. **HANDLE WITH CARE.**

Those with pacemakers or ICD's must stay at least 25 cm (10 in) away at all times.

7.2. Cleaning

General cleaning of all components is important to keep the system working properly. All components that do not have wiring or cables are completely waterproof. Components can be washed with warm water, dish soap and a medium bristle brush. Before using the scanner, ensure that all connectors are free of water and moisture.

TIP: All components with wiring, cables or electrical connections are splashproof but not submersible.

NOTE: Never use strong solvents or abrasive materials to clean your scanner components.

7.3. Maintenance Schedule

The **SKOOT•X** system must be maintained according to the following schedule.

Task	Frequency
<u>Inspect cables and connectors</u> Inspect the umbilical cable, the control cable and the power controller cable for damage. Have any damaged cable repaired by a qualified person or replace the cable assembly as necessary. Inspect all connectors for damage or moisture. Straighten bent pins. Dry connectors before using.	Every Use
<u>General cleaning</u> Ensure that the scanner stays relatively clean by wiping off any excess dirt or other contaminants after every use.	Every Use
<u>Clean the drive wheels</u> Debris will collect on the magnetic wheels. Remove this debris before every use. An effective cleaning method uses adhesive backed tape (<i>e.g. duct tape</i>) to 'pull' the debris off the wheels.	Every Use

TROUBLESHOOTING

8.1. Startup Issues

Two messages are possible in the event of a startup issue: **Joystick Off Centre** or **Checking Network**.

8.1.1. Joystick Off Centre

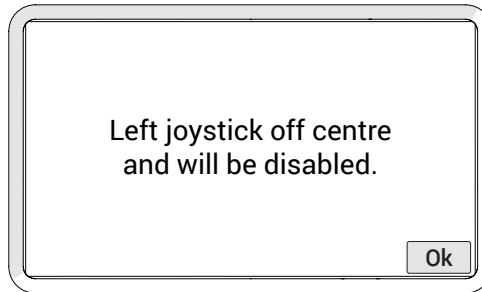

Fig. 128 - Joystick off centre screen

Upon system startup, the joystick positions are detected. When a joystick is detected outside the centre position, the **Joystick Off Centre** screen displays, indicating the joystick will be disabled. Press **Ok** to continue system startup. All system functions will work normally with the exception of movements that require joystick operation.

Ensure the handheld controller's joysticks are free of interference and reset the system power to enable joystick control.

If no interference of the joystick is present, the joystick calibration may need to be performed (see "Joystick Calibration Screen" on page 66)

8.1.2. Checking Network

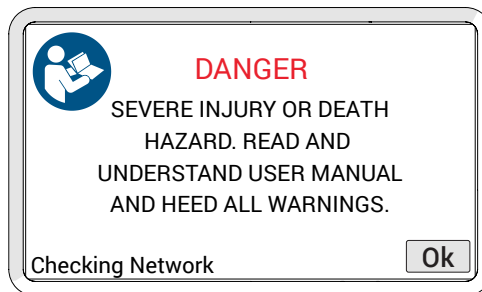

Fig. 129 - Checking network screen

During startup, the system initializes the communications to all the devices on the network. If the network communication fails for any reason, the **Checking Network** message will appear and remain on screen.

Likely causes of this failure:

1. No devices are connected to the network.
2. A problem with one of the devices.
3. Cable issue causing the entire network to fail.

Check the connections of the devices or try removing one device at a time from the system to isolate the problem device.

NOTE: Always turn off the system power before connecting or disconnecting any devices.

8.2. Startup Override

A system maintenance mode may be accessed to correct system issues. Enter the maintenance mode by pressing the handheld controller D-pad while system power is activated. Continue pressing the handheld controller D-pad until the **Startup Override** screen appears.

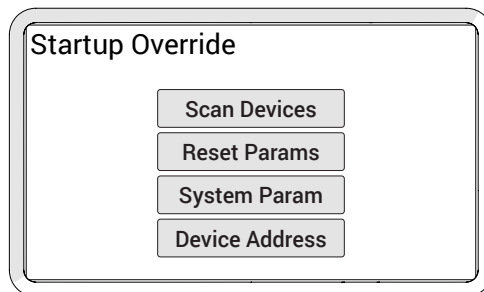

Fig. 130 - Startup override screen

8.2.1. Scan Devices

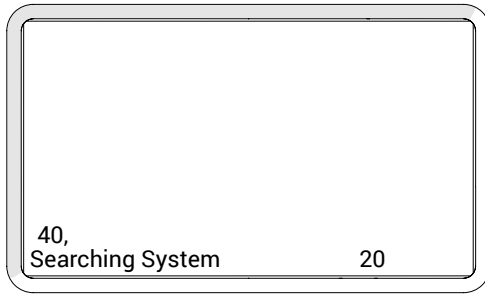

Fig. 131 - Searching System screen

This utility scans the system network for devices. All possible device addresses and speeds are scanned. As devices are found, the address of the devices is displayed. When the scanning is complete, power to the system must be cycled.

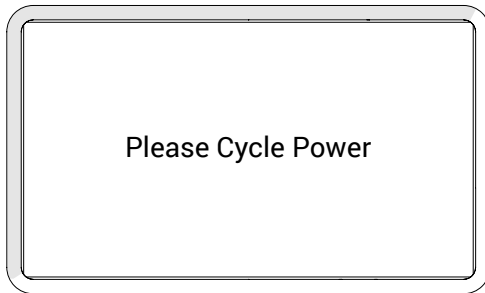

Fig. 132 - Cycle power screen

When a device is connected to the system but is not detected, this most likely indicates an internal device problem.

8.2.2. Reset Parameters

If the system parameters become corrupt or a change is made that prevents the system from functioning properly. All system parameters may be restored to their factory settings by selecting this option. When pressing the **Reset Params** button, the changes occur immediately. Power will need to be cycled for the reset to be complete.

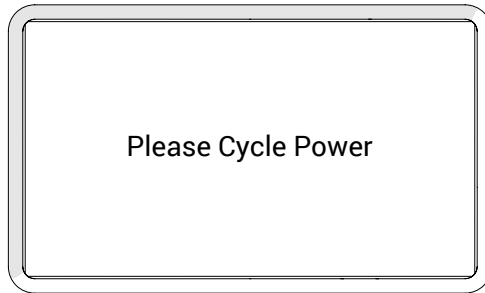

Fig. 133 - Cycle power screen

8.2.3. System Parameters

System parameters are factory set to control a variety of functions. These parameters can not be modified. However, special circumstances may occur when modification of these parameters could be recommended by the manufacturer.

Instructions for making changes to the system parameters will only be provided when deemed necessary by the manufacturer.

8.2.4. Device Address

Instructions for making changes to the system parameters will only be provided when deemed necessary by the manufacturer.

8.3. Additional Issues

Problem	Possible Cause	Solution
Handheld controller display does not activate	Input power requirements not met.	Ensure input power meets requirements. (see <i>“Power Requirements”</i> on page 6)
	The handheld controller not plugged into power controller.	Plug handheld controller into power controller. Ensure connectors are dry, clean and connector pins are not bent.
	Umbilical cable not properly connected.	Check umbilical cable connections at both ends. Ensure connectors are dry, clean and connector pins are not bent.
	SKOOT•X system not started.	Start the SKOOT•X system. (see <i>“System Startup”</i> on page 42)
The handheld controller display is activated, yet the crawler does not drive	Damaged components in the handheld controller, crawler, power controller or cabling.	Contact manufacturer. (see <i>“Jireh Industries Ltd.”</i> on page 2)
	Handheld controller is not in the correct mode for driving.	(see <i>Operation</i> on page 52 for additional details).
The system displays “Please Wait – Motor Moving” when power is applied.	The crawler is moving when power is applied due to an external force (<i>gravity, etc.</i>).	Manually stop the crawler movement. The crawler must be stationary for system initialization to be performed.

For technical assistance (see *“Technical Support”* on page 76).

SERVICE AND REPAIR



WARNING! ELECTRICAL SHOCK

HAZARD. Disconnect the power controller when servicing the equipment. The power controller is powered even when the E-Stop push-button is latched in the off position.



WARNING! MAGNETIC MATERIAL.

The wheels of the crawler produce an extremely strong magnetic field which may cause failure or permanent damage to items such as watches, memory devices, CRT monitors, medical devices or other electronics.



Tools, magnets and metal objects can cut, pinch or entrap hands and fingers. **HANDLE WITH CARE.**

Those with pacemakers or ICD's must stay at least 25 cm (10 in) away at all times.



WARNING! DO NOT DISASSEMBLE.

No user-serviceable parts. Disassembling any of the components in this product, beyond the instructions in this user manual, could void the regulatory certifications and/or effect the safety of the product.

9.1. Technical Support

For technical support, contact Jireh Industries (see "Jireh Industries Ltd." on page 2).

SPARE PARTS

To order accessories or replacement parts for your **SKOOT•X** system. (contact Jireh Industries Ltd. on page 2)

NOTE: These drawings are for parts order. This is not a list of kit contents.

10.1. Crawler

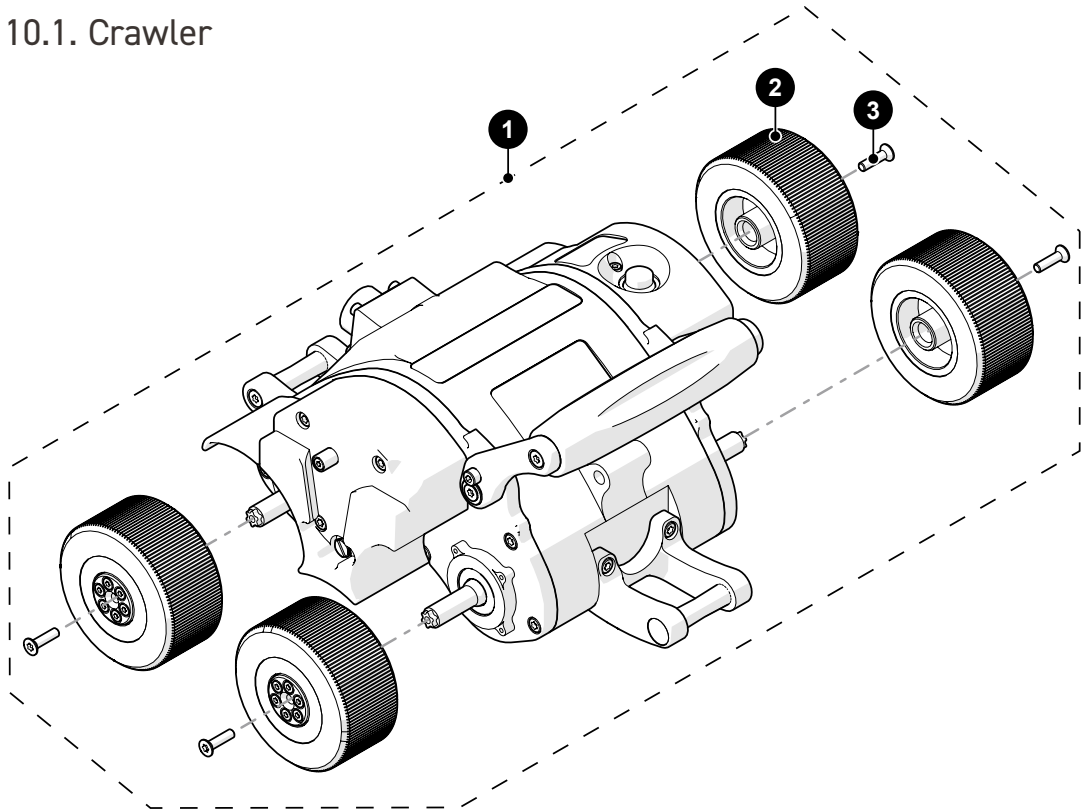

Fig. 134 - SKOOT•X crawler spare parts

BOM ID	Part #	Description
1	EBA005	SKOOT•X Crawler (Chain)
2	EJS009	Motorized non-magnetic wheel
3	MD400-016	FHCS-TX, M4x0.7 x 16mm

10.2. Crawler (Magnetic)

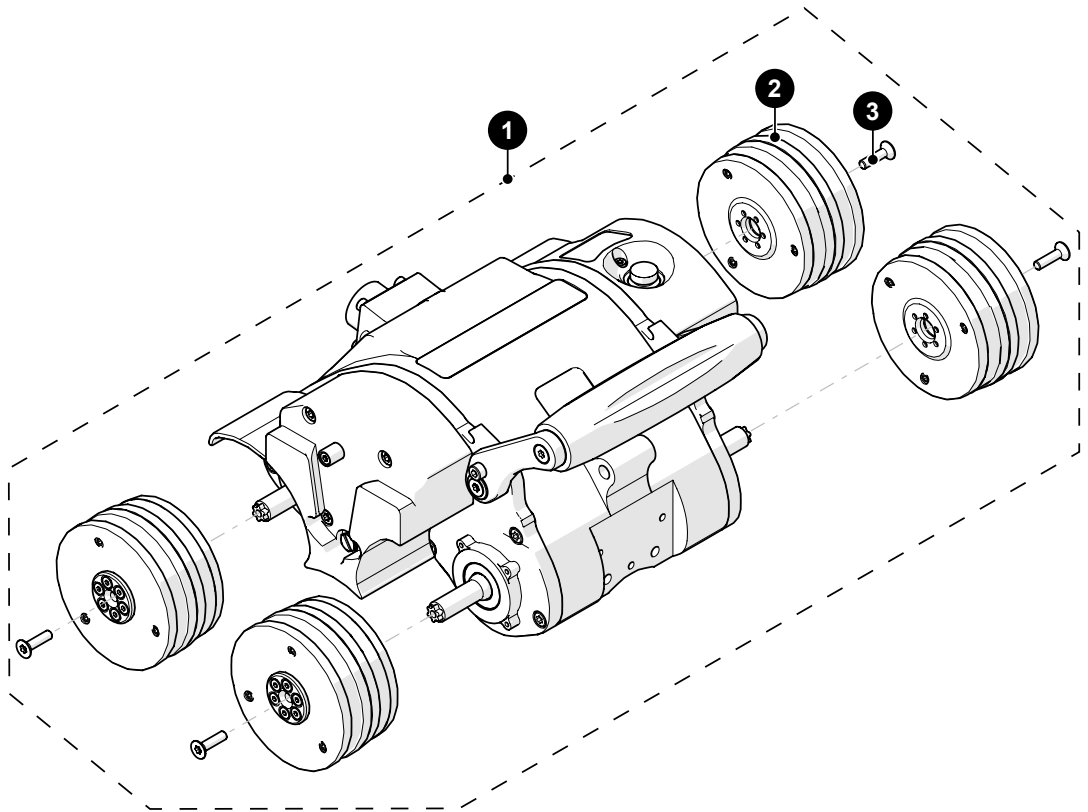

Fig. 135 - SK00T-X crawler (magnetic) spare parts

BOM ID	Part #	Description
1	EBA011	SKOOT•X Crawler (<i>Magnetic</i>)
2	CXS005	Motorized magnetic wheel
3	MD400-016	FHCS-TX, M4x0.7 x 16mm

10.3. Kit Components

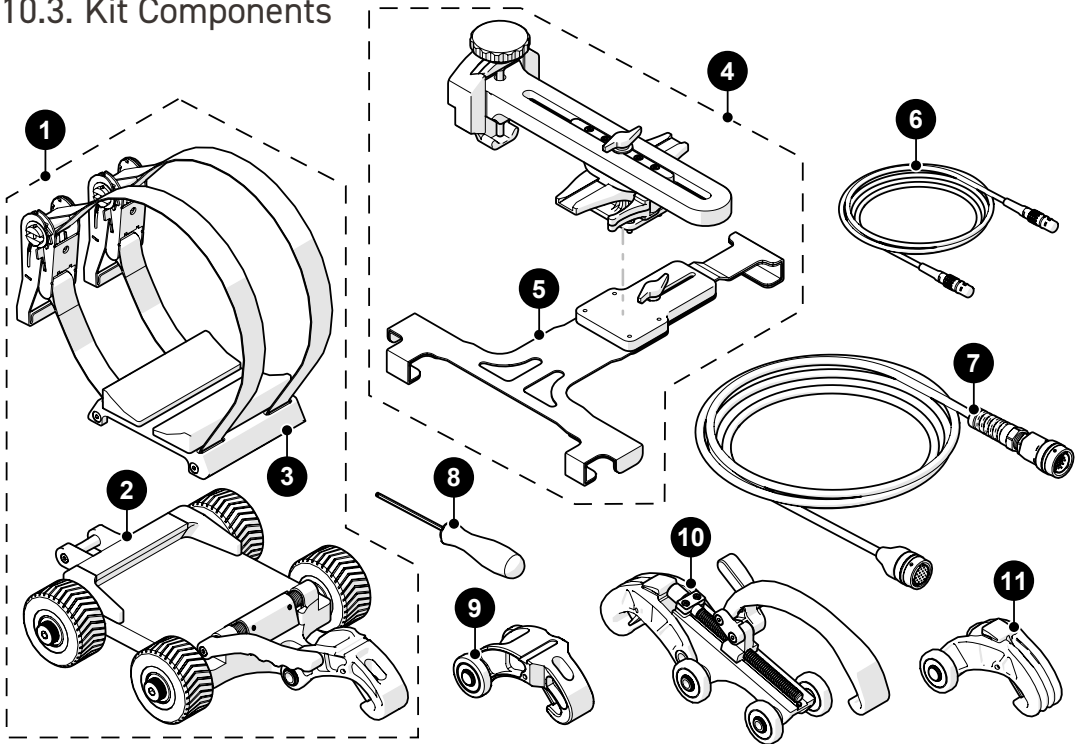

Fig. 136 - Kit components spare parts

BOM ID	Part #	Description
1	EBA009	Source cart
2	EBS029	Source cart base
3	EBS040	Mounting plate
4	EBA001-X	Detector bracket (<i>see Detector Bracket Type</i>)
5	EBS034-	(<i>see Detector Bracket Type</i>)
6	UMA017-	Auxiliary cable
7	UMA022-	Umbilical
8	EA414	Hex driver: 3 mm (0.118 in)
9	EES011	Red dovetail link
10	EBS042	Buckle
11	EES004	Chain link

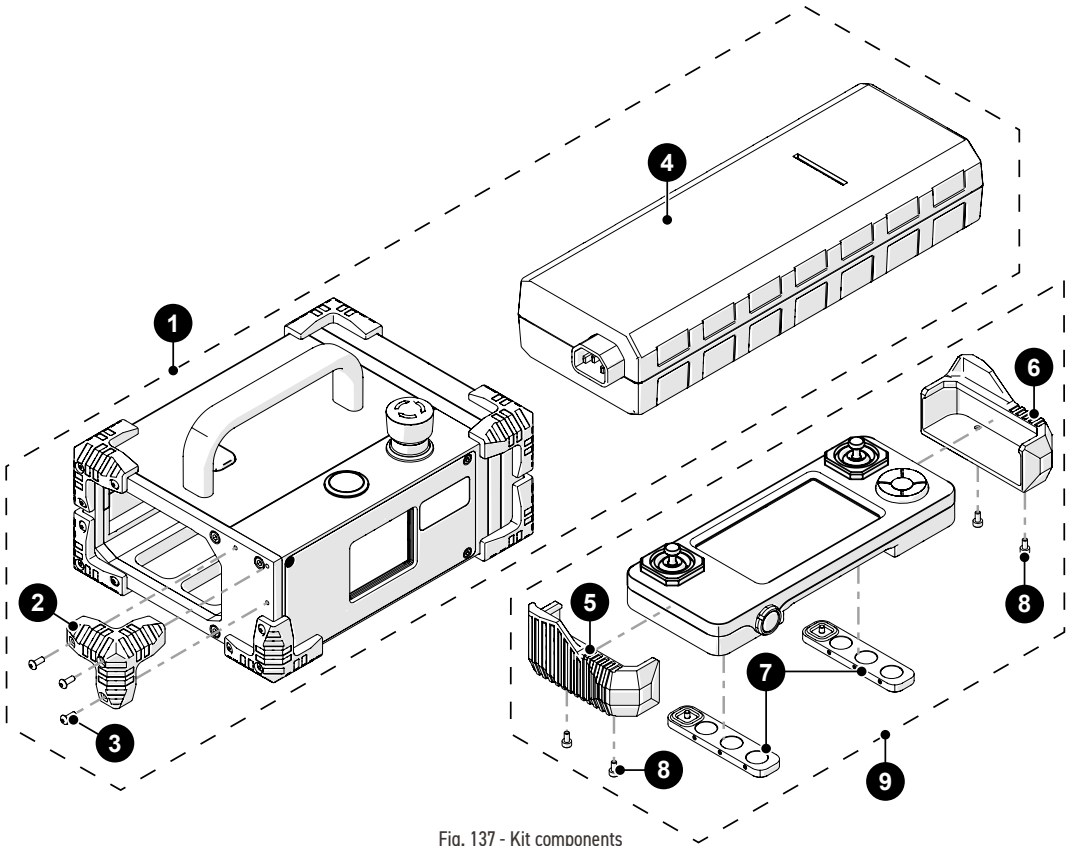
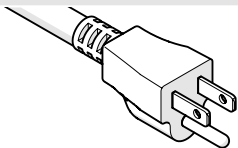
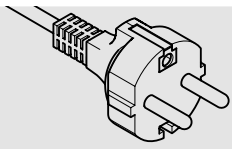
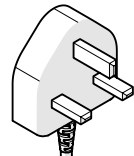

Fig. 137 - Kit components

BOM ID	Part #	Description
1	CXA040-	Power controller (<i>see Power Cord Type</i>)
2	DY0011	Rubber bumper
3	MD072-008	BHCS, M3x0.5 X 8mm, SST
4	CXS122	Power supply
5	DM0067-L	Handheld controller bumper (<i>left</i>)
6	DM0067-R	Handheld controller bumper (<i>right</i>)
7	DMS005	Handheld controller magnet holder
8	MD049-006	SHCS, M3x0.5 X 6mm, SST
9	DMA006	Handheld controller

10.3.1. Power Cord Type

Connector Type	Part #	Power Cord	
N	SL032	North American	
E	SL039	European	
U	SL059	United Kingdom	
Z		No Cord	

10.3.2. Detector Bracket Type

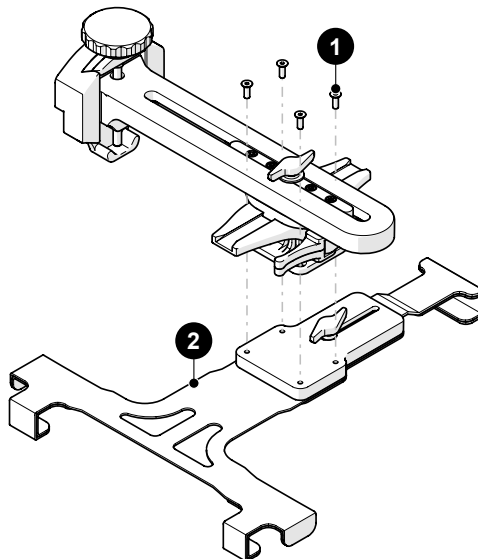
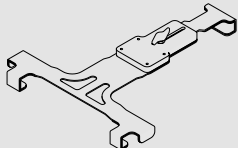
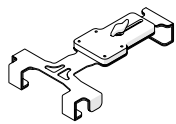
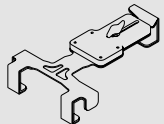
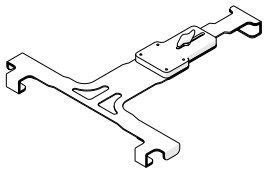
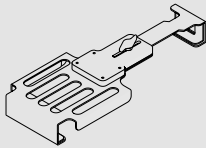
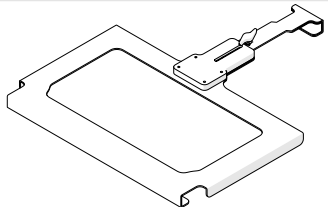

Fig. 138 - Detector bracket type

BOM ID	Part #	Description	
1	MD029-012	FHCS, M4x0.7 X 12mm, SST	
2	EBS034-01	NOVO 15 detector bracket	
	EBS034-02	Teledyne ICM Go-Scan 1510HR/XR detector bracket	
	EBS034-03	Vidisco BOLT 6K detector bracket	
	EBS034-04	Vidisco Guardian 12 detector bracket	
	EBS034-05	DÜRR 1024 detector bracket	
	EBS034-06	Carestream HPX-DR 3543 detector bracket	

10.4. Backpack

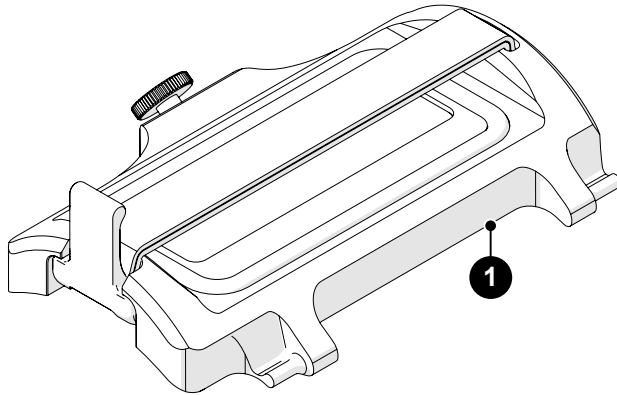

Fig. 139 - Backpack

BOM ID	Part #	Description
1	EBS043	SKOOT•X Backpack

10.5. Installation/Removal Mat

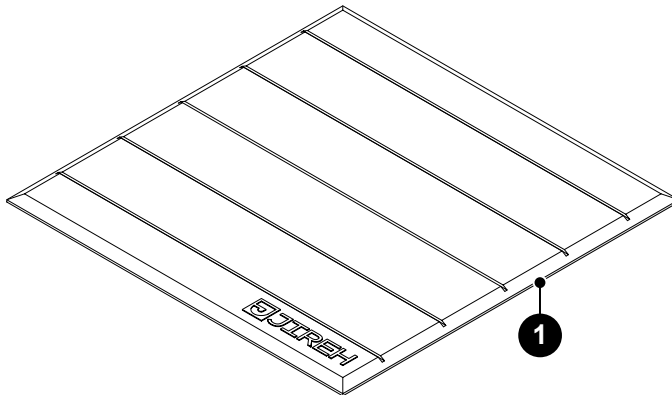

Fig. 140 - Installation/removal mat

BOM ID	Part #	Description
1	AAS061	Installation/removal mat

10.6. Cases

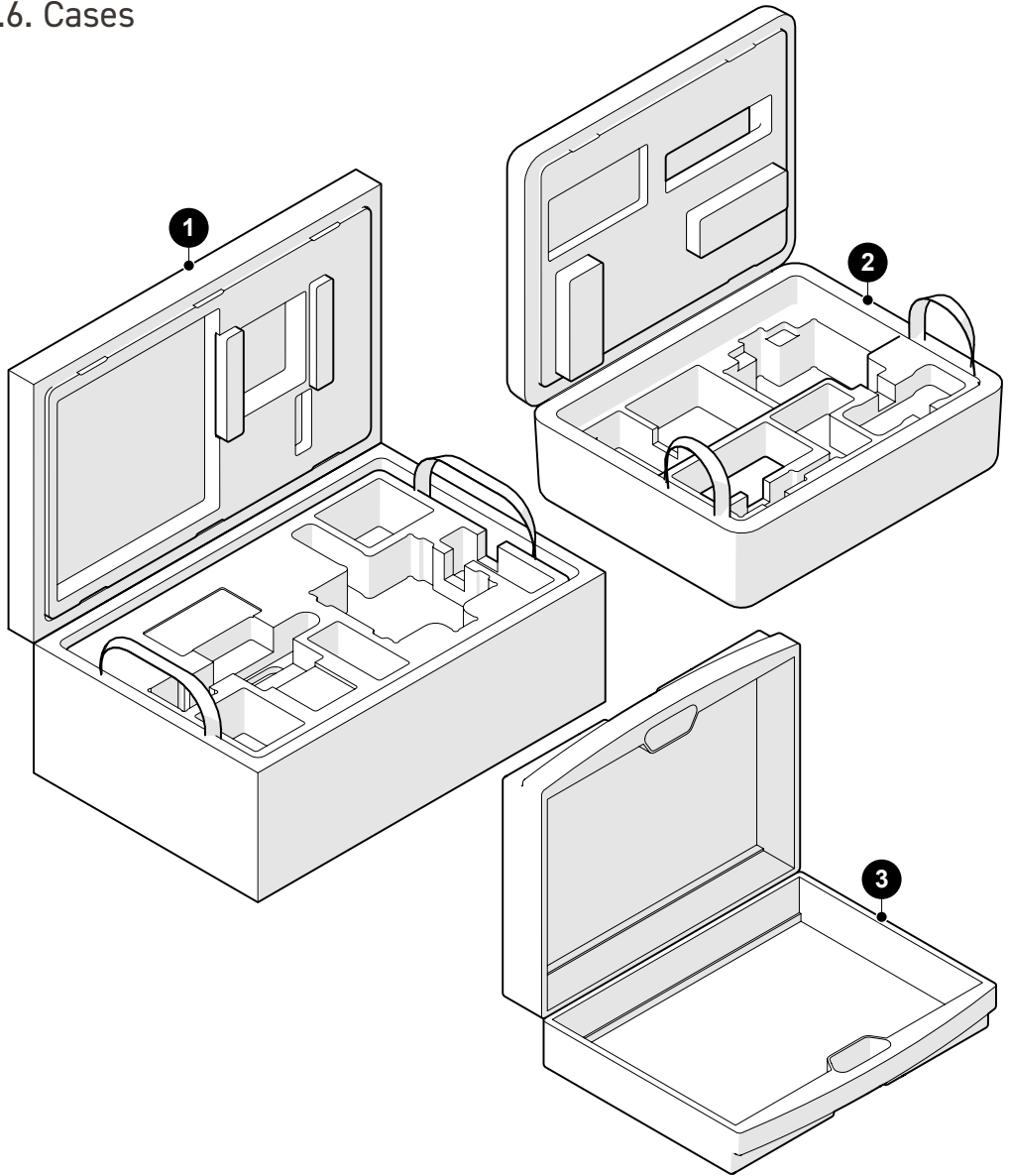

Fig. 141 - Cases

BOM ID	Part #	Description
1	EBA010	SKOOT•X Case: chain links and detector
2	EBA007	SKOOT•X Case: crawler, power controller
3	EA421	Umbilical Case

10.7. Accessories

10.7.1. Cable Management, Dovetail Mount

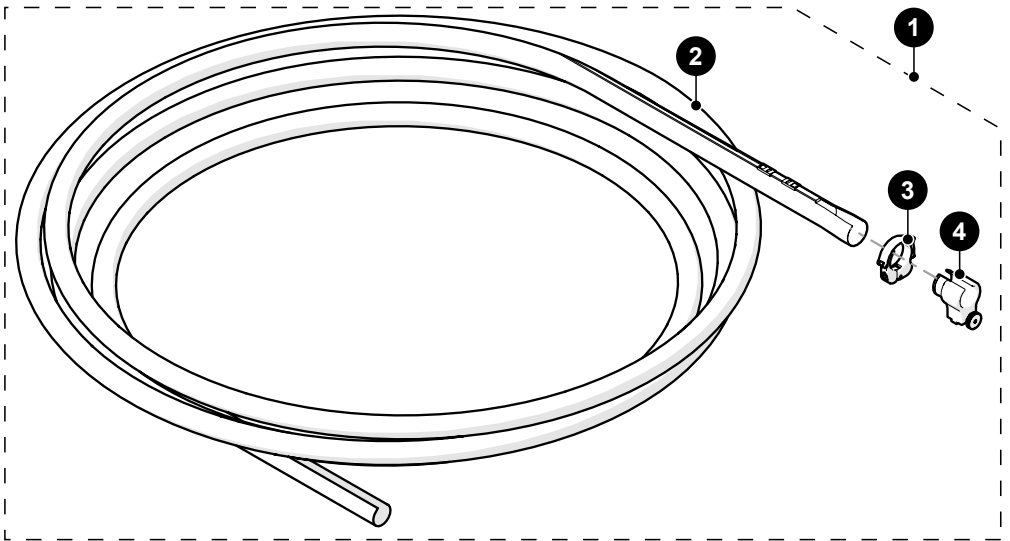

Fig. 142 - Cable management

BOM ID	Part #	Description
1	CES044-29.5	Cable management: dovetail mount
2	CX0147	Cable management sleeving: 29.5 m (96.8 ft) length
3	CES066	Cable management clamp
4	CES067	Cable management mount, dovetail mount

DISPOSAL

WEEE Directive

In accordance with European Directive on Waste Electrical and Electronic Equipment (WEEE), this symbol indicated that the product must not be disposed of as unsorted municipal waste but should be collected separately. Refer to Jireh Industries for return and/or collection systems available in your country.



LIMITED WARRANTY

WARRANTY COVERAGE

Jireh Industries warranty obligations are limited to the terms set forth below: Jireh Industries Ltd. (“Jireh”) warrants this hardware product against defects in materials and workmanship for a period of THREE (3) YEARS from the original date of purchase. If a defect exists, at its option, Jireh will (1) repair the product at no charge, using new or refurbished replacement parts, (2) exchange the product with a product that is new or which has been manufactured from new or serviceable used parts and is at least functionally equivalent to the original product, or (3) refund the purchase price of the product. A replacement product/part assumes the remaining warranty of the original product or ninety (90) days from the date of replacement or repair, whichever provides longer coverage for you. When a product or part is exchanged, any replacement item becomes your property, and the replaced item becomes Jireh’s property. When a refund is given, your product becomes Jireh’s property.

OBTAINING WARRANTY SERVICE

To utilize Jireh’s warranty service, you must ship the product, at your expense, to and from Jireh Industries. Before you deliver your product for warranty service, you must phone Jireh and obtain an RMA number. This number will be used to process and track your product. Jireh is not responsible for any damage incurred during transit.

EXCLUSIONS AND LIMITATIONS

This Limited Warranty applies only to hardware products manufactured by or for Jireh Industries. This warranty does not apply: (a) to damage caused by accident, abuse, misuse, misapplication, or non-Jireh products; (b) to damage caused by service (including upgrades and expansions) performed by anyone who is not a Jireh Authorized Service Provider; (c) to a product or a part that has been modified without the written permission of Jireh.

Jireh Industries Ltd.
53158 Range Road 224
Ardrossan, AB T8E 2K4
Canada

Phone: 780-922-4534

jireh.com

All brands are trademarks or registered trademarks of their respective owners and third-party entities.

Changes or modifications to this unit or accessories not expressly approved by the party responsible for compliance could void the user's authority to operate the equipment.

All specifications are subject to change without notice.

© 2022 Jireh Industries Ltd.

APPENDIX

13.1. SKOOT·X Chain Configuration Setup Chart

SKOOT·X	PIPE SIZE				Source Cart	X		Dovetail Link	Y		Buckle
	Min (cm)	Max (cm)	Min (in)	Max (in)		# of Links	Crawler		# of Links		
						EBS029	EES004		EBA005	EES011	
Setup Chart	20.3	21.6	8.0	8.5	Source Cart - EBS029	0	SKOOT·X Crawler - EBA005	**	0	* Buckle - EBS042	
	21.3	25.1	8.4	9.9		1		**	0		
	24.9	28.4	9.8	11.2		2		0			
	28.4	31.8	11.2	12.5		3		0			
	31.8	35.1	12.5	13.8		3		1			
	35.1	38.4	13.8	15.1		4		1			
	38.1	41.4	15.0	16.3		5		1			
	41.1	44.5	16.2	17.5		5		2			
	44.2	47.5	17.4	18.7		5		3			
	47.2	50.3	18.6	19.8		6		3			
	50.0	53.3	19.7	21.0		6		4			
	53.1	56.4	20.9	22.2		7		4			
	55.9	59.2	22.0	23.3		7		5			
	58.7	62.0	23.1	24.4		8		5			
	61.7	64.8	24.3	25.5		9		5			
	64.5	67.6	25.4	26.6		9		6			
	67.3	70.6	26.5	27.8		10		6			
	70.1	73.4	27.6	28.9		10		7			
	72.9	76.2	28.7	30.0		11		7			
	75.7	79.0	29.8	31.1		11		8			
78.5	81.8	30.9	32.2	12	8						
81.3	84.6	32.0	33.3	12	9						
84.1	87.4	33.1	34.4	13	9						
86.9	90.2	34.2	35.5	13	10						
89.9	93.0	35.4	36.6	14	10						
92.5	95.8	36.4	37.7	14	11						
95.3	98.6	37.5	38.8	15	11						
98.0	101.3	38.6	39.9	15	12						
100.8	104.1	39.7	41.0	16	12						
103.6	106.9	40.8	42.1	16	13						
106.4	109.5	41.9	43.1	17	13						

Example: 41.1 - 44.5 cm (16.2 - 17.5 in) setup

Note to Customer: * Buckle hooked to Source Cart in all applications
 ** Dovetail link moved to X side on pipe diameters under 25.2 cm (9.8 in)



Jireh Industries Ltd.
53158 Range Road 224
Ardrossan, Alberta
Canada
T8E 2K4

780-922-4534

jireh.com