

ACFM[®] PROBE CATALOG

TECHNICAL SPECIFICATIONS



TOPSIDE ACFM PROBES

UNDERWATER ACFM PROBES

ACFM PROBES COMPARISON

TABLE OF CONTENTS

TOPSIDE ACFM PROBES

5Introduction to SENSU 2 Topside Probes
6 SENSU 2 Compliant Array Probe
7 SENSU 2 3BZ Fillet Weld Array Probe
8 SENSU 2 High Temperature ACFM Probes
9 SENSU 2 Weld Probe
10 SENSU 2 Mini Pencil Probe

UNDERWATER ACFM PROBES

11 Introduction to SENSU 2 UW Probes
12 SENSU 2 Diver Mini Array Probe
13 SENSU 2 Weld Probe
14 SENSU 2 Diver Ground Weld Probe
15 SENSU 2 Tight Access Probe
16 SENSU 2 Mini Pencil Probes
17 SENSU 2 Micro Pencil Probes

ACFM PROBES COMPARISON

18 - 19 ACFM Probe List
---------	-----------------------





ELEVATING INDUSTRY STANDARDS WITH EDDYFI TECHNOLOGIES

OVERVIEW

Eddyfi Technologies offers a wide range of Alternating Current Field Measurement (ACFM®) probes for the detection and sizing of surface breaking cracks in a range of metals. These include simple single-sensor probes through to advanced multi-sensor arrays to suit all purposes, sizes, angles and underwater plus a customised option, meaning that Eddyfi can supply the right equipment needed for your particular inspection project.

Our standard frequency probes have been developed to optimise performance on carbon steel components and welds. This probe range also includes high frequency versions of many of our standard probes, which are used for inspecting non-magnetic materials.

Our range of probes can be used in a variety of situations, from site inspection undertaken by abseilers, to thread inspection in workshops.

The ACFM® method can utilise a variety of different probe types, which are selected according to the application. When selecting a probe, consideration should be given to material type, access and geometry, weld quality, productivity, temperature and minimum detectable defect size.

SENSITIVITY

SENSU 2 ACFM probes, combined with the latest generation ACFM instrumentation, provide higher signal to noise ratios and better sensitivity than previous generations of ACFM probes. Laboratory test have demonstrated SENSU 2 ACFM probes can detect cracks 5mm long x 0.5mm deep and above on a good surface.

With this increase in performance, standard ACFM probes are generally recommended for most applications, even where micro probes were used previously. However, SENSU 2 probes with smaller, micro noses are still available for the applications where the ultimate in ACFM sensitivity is still required.

MATERIAL TYPE

ACFM® can be used on most conductive metallic components for the detection of surface breaking defects, either on plain metal or through coating such as paint, epoxy or metallic coatings. Whilst it excels at the detection and sizing of cracks in and around welded ferrous components, it can also be used for the detection of environmental cracking in plain sections, pressure vessels, pipework and for inspecting non-magnetic metals.

The type of material to be inspected is a key factor in the selection of an ACFM probe:

- Ferritic Carbon Steels should normally be inspected using probes with a 5kHz operating frequency.
- Austenitic Steels, aluminium, titanium and other non-magnetic materials should normally be inspected using probes with a 50kHz operating frequency.
- Galvanized steel structures should be inspected with any 5KHz single element ACFM Sensu 2 probe models with the "GS" designation, which incorporate the required parameters to reliably detect and size cracks in galvanized steel.

Many ACFM probes are available in either 5kHz or 50kHz variants to suit the component material.

GEOMETRY AND ACCESS

ACFM probes are available in several common body styles to allow the probe access for a variety of common geometries and components.

Where a butt-weld, lap-weld or plain section are to be inspected, multi-element array probes can be used to cover large areas swiftly for maximum productivity. Details of some common types are contained in this document.

The Weld probes are designed primarily for scanning along weld toes but can also be used to inspect for defects in general components. The Weld probe type should be used wherever access allows because it is the most stable probe to deploy and has the largest field inducer, making it best for accurate sizing, particularly on deep defects.

The Pencil probes are used in places that the Weld probe cannot gain access and are particularly useful at plate edges where their smaller induction fields produce less of a geometry effect. Pencil probes are available with three different nose orientations. The nose orientation should be chosen depending on the access requirement.

Probes are also available for deployment underwater. These are available either with a 5m cable and connectors for a U41D/DA instrument or with a 50m long cable with a connector for use with AMIGO2.

The AMIGO2 probes are designed for use in shallow water applications where the AMIGO 2 Instrument remains dry and the long probe cable is used to deploy the probes underwater.

For greater depth, the U41D/DA probes are rated for 300m operation.

NOTE: Only probes specified as underwater probes can be used for this type of inspection.

STANDARD ACFM® PROBES

- Feature a pair of Bx and Bz sensors wound concentrically.
- Generally have a sensitive width of 15mm, centred on the scan line, and are relatively insensitive to small liftoff variations and small variations in weld profile, spatter etc.

MICRO PROBES

- Used for applications where the highest sensitivity is required, micro probes are available in the three pencil probe configurations.
- Contain smaller, side by side sensors which provide improved detection for very short and shallow defects. However, this can create skewed butterfly loops with short defects.
- Have a typical sensitive width of 10mm and are generally more susceptible to noise generated by small liftoff variations and variations in weld profile, spatter etc compared to their standard Pencil probe counterparts. Because of this, Micro Pencil probes should only be used where the surface is smooth and the additional sensitivity is required.

UNDERSTANDING PART NUMBERS

STANDARD PROBES

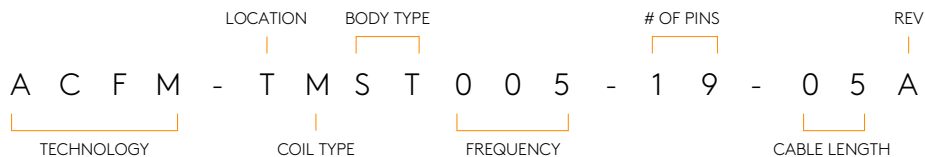

ARRAY PROBES



SENSU 2 TOPSIDE PROBES

INTRODUCTION

Eddyfi's functional design philosophy continues in the new and innovative ACFM® probe range SENSU 2, which partners Amigo2 to enable much faster inspections, pristine signals, and higher SNR.

As "intelligent" probes, the SENSU 2 range stores configuration information, features convenient buttons and provides instant feedback of scanning status whilst in use. Faster than the legacy probes - up to 8 outputs

- Faster than the legacy probes - up to 8 outputs
- Connectorized for convenience. Easy to swap probe cables
- IP65 rated
- All probe data stored in probe's memory
- Buttons to start or stop a scan
- LEDs to indicate scan status
- Ergonomic design



SENSU 2 COMPLIANT ARRAY PROBE

COMPATIBLE WITH AMIGO 2

Designed to inspect ferromagnetic steel, this 5kHz probe has 8 or 16 spring loaded modules containing Bx, By and Bz coils pair that comply to a profile. Each module can travel independently through a distance of approximately 12mm (0.47in). This makes the probe ideal for inspecting butt or lap welds with raised profile weld caps since, depending on the cap width, the probe can inspect both toes and the full cap in one pass as it scans a strip approximately 45/90mm (1.77/3.5in) wide.

The probe also features a wheeled encoder, for position feedback and rapid sizing of defects in any orientation, on-board start/stop and mark buttons.

- Dual fields
- Integrated encoder
- Integrated buttons
- Max cable length: 50m
- Coverage: 45 or 90mm

COMPATIBLE CABLES

- SENSU-2-HS-CBL-5M-
- SENSU-2-HS-CBL-20M-
- SENSU-2-HS-CBL-50M

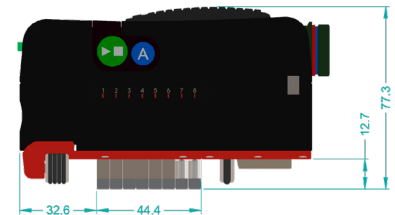
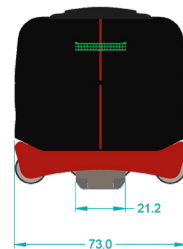
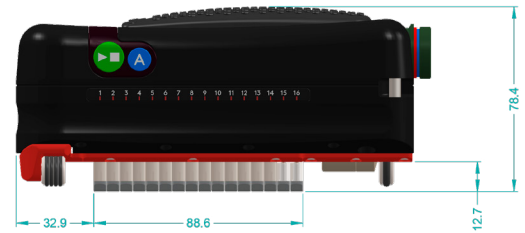
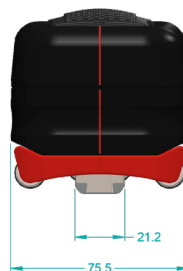

PART NUMBER	RANGE	DESCRIPTION	FREQ	NOSE CONFIG	COVERAGE
ACFM-TUCA005-16T-40	SENSU 2	Compliant array probe, 16 rows	5kHz	Micro	90
ACFM-TUCA005-08T-40A	SENSU 2	Compliant array probe, 8 rows	5kHz	Micro	45

COMPATIBLE WITH	APPLICATIONS	BENEFITS
AMIGO 2	Butt and lap weld inspection. Plain areas on flat or curved components.	Compliant profile, ideal for raised weld caps Scan strip up to approx 45mm (1.77in) or 90mm (3.5in) wide.

SENSU 2 3BZ FILLET WELD ARRAY PROBE

COMPATIBLE WITH AMIGO 2

Designed to inspect ferromagnetic steel fillet welds, this 5kHz probe has three mini ACFM sensors mounted in a rugged monobloc ceramic nose. The sensors are aligned with the weld cap and toes, enabling single pass coverage of fillet welds with approximately 16mm (5/8in) wide caps, extending 12mm (0.5in) into the heat-affected zones (HAZ). The probe also features 3BZ sizing technology for rapid sizing of cracks, onboard start/stop and mark buttons.

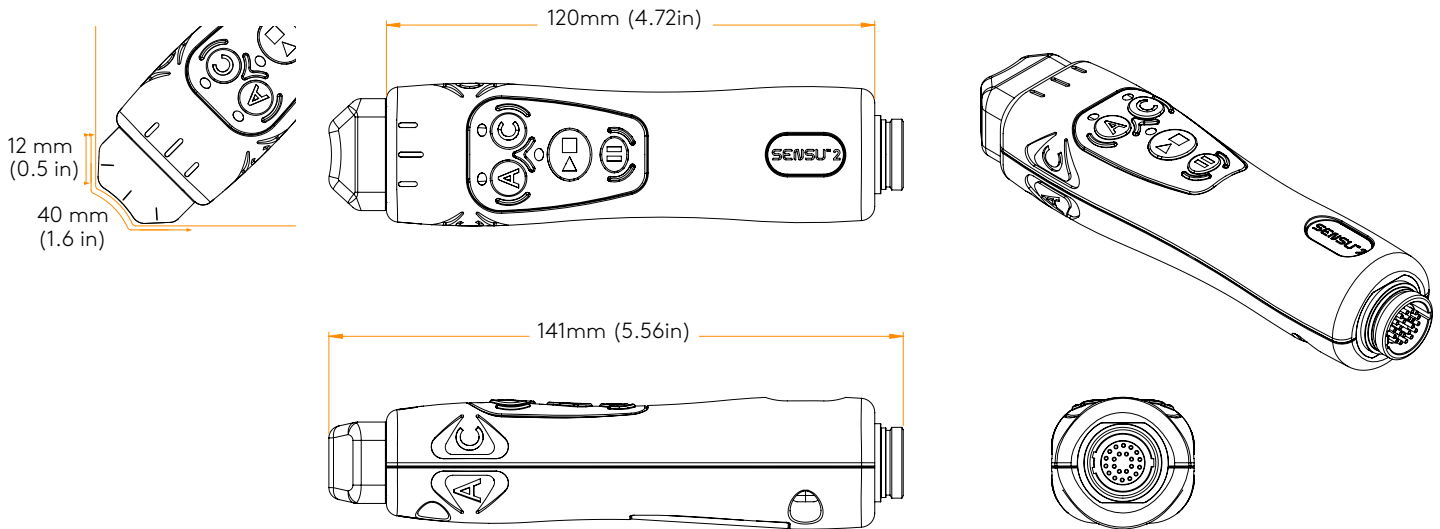

ACFM-TMXA005-03X-22

Sensor configuration	3 rows of mini ACFM sensors with 3Bz sizing technology
Frequency	5 kHz (for ferromagnetic weld inspections)
Nose configuration	Straight
Coverage	40mm (1.6in) over fillet welds Extending 12mm (0.5in) into the heat-affected zones (HAZ), measured from the weld toes
Compatible cables	SENSU-2-STD-CBL-5M, SENSU-2-STD-CBL-20M, SENSU-2-STD-CBL-50M

COMPATIBLE WITH	APPLICATIONS	BENEFITS
AMIGO 2	Fillet welds in railcars, tanks, civil structures, mining equipment, etc.	Rapid inspection of coated and unprepared fillet welds.

SENSU 2 HIGH TEMPERATURE ACFM PROBES

COMPATIBLE WITH AMIGO 2

Designed to inspect ferromagnetic and non-ferromagnetic steel components operating at temperatures up to 500°C (932°F), this probe is built around a mini ACFM sensor and makes use of heat resistant materials, an overheating warning system, air cooling, and high temperature calibrations. The probe also integrates the 3BZ sizing technology for rapid and easy sizing of cracks in hot components.

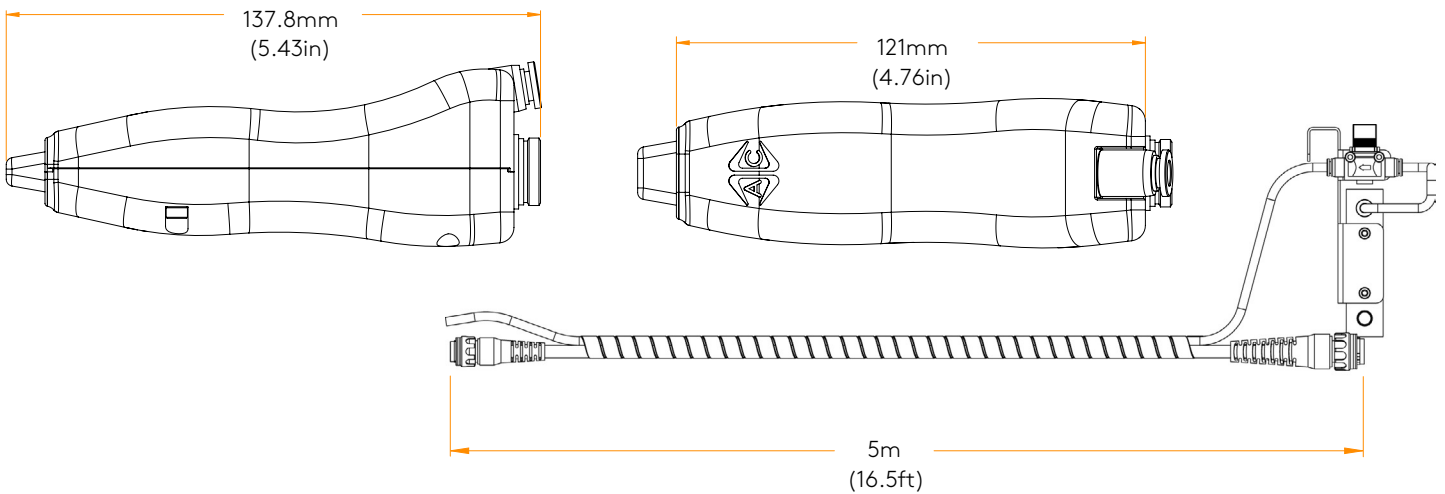

ACFM-HMST005-22 (5KHZ VERSION) - ACFM-HMST050-22 (50KHZ VERSION)

Sensor configuration	Mini ACFM sensor, 3Bz sizing technology
Frequency	5 kHz probe for ferromagnetic weld inspections, 50 kHz probe for non-ferromagnetic weld inspections
Nose configuration	Straight, active temperature sensing and red LED feedback for overheating internals
Coverage	15mm (0.6in)
Compatible cables	SENSU-2-HT-CBL-5M
Maximum component temperature	500°C (932°F)
Typical scan times at 500°C (932°F)	Scan time: ~12s, Duty cycle: ~50%

Requires external air supply to 1/8 NPT or BSP pipe thread fittings

COMPATIBLE WITH	APPLICATIONS	BENEFITS
AMIGO 2	Hot pipework, vessels, pressure vessels, emulsion pipelines, pre/post-inspection of hot tapped weldolets and split tees, welding inter-pass inspection, etc.	Efficient crack detection in ferromagnetic and non-ferromagnetic components operating at temperatures up to 500°C (932°F). Fast and easy crack sizing (3BZ technology).

SENSU 2 WELD PROBE

COMPATIBLE WITH AMIGO 2

The probe of choice for generic ferritic or austenitic weld inspection.

Features stabilizers and a wider field. The wider field enables deeper sizing down to 25mm (0.98in) deep.

Available for the inspection of:

- Ferritic Welds (5kHz)
- Austenitic Welds (50kHz)
- Galvanized steel welds (With ACFM-TMWP005-GS-22 probe)

COMPATIBLE CABLES

- SENSU-2-STD-CBL-5M
- SENSU-2-STD-CBL-20M
- SENSU-2-STD-CBL-50M

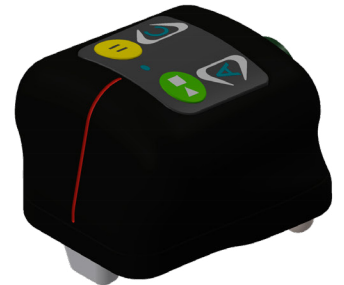
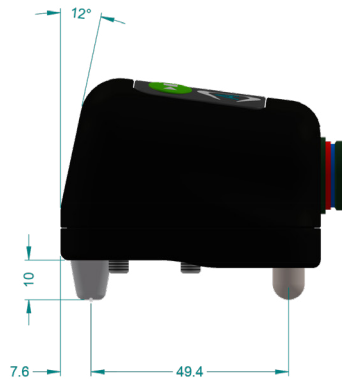
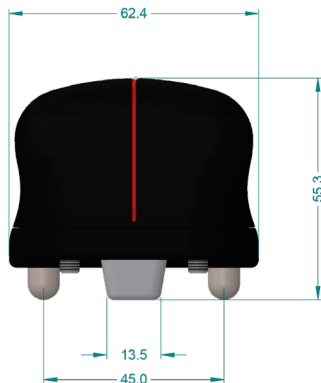
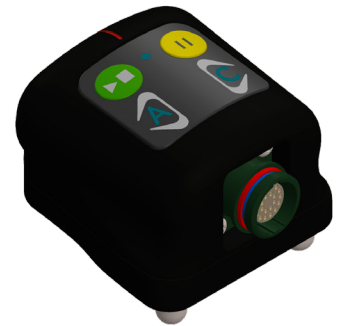
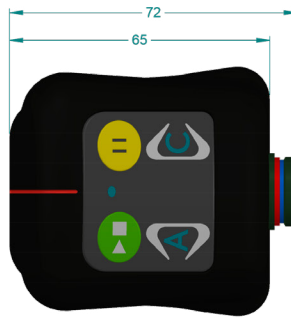

PART NUMBER	RANGE	DESCRIPTION	FREQ	NOSE CONFIG	COVERAGE
ACFM-TMWP005-22A	SENSU 2	Topside weld probe	5kHz	N/A	15
ACFM-TMWP005-GS-22	SENSU 2	Topside weld probe with Galvanized steel option	5kHz	N/A	15
ACFM-TMWP050-22A	SENSU 2	Topside weld probe	50kHz	N/A	15

COMPATIBLE WITH	APPLICATIONS	BENEFITS
AMIGO 2	Butt and lap weld inspection. Sizing in thick wall components.	Stabilizers Wider field Coverage of 15mm (0.59in)

SENSU 2 MINI PENCIL PROBE

COMPATIBLE WITH AMIGO 2

The Mini-Pencil probe range maintains the sensitivity of the standard Weld Probes, but have the advantage of being able to access restricted areas and areas of weld associated with rat holes in structures.

They are less prone to signal variations near plate edges, but are less accurate for depth sizing deep defects (>10mm/0.39in).

The right angle nose type is ideal for inspecting through rat-holes, or for longitudinal cracks inside pipes.

The straight nose probe is ideal for difficult access areas while the transverse nose is ideal for circumferential cracks inside pipes.

For the inspection of galvanized steel structures, probes with the "GS" designation should be used.

COMPATIBLE CABLES

- SENSU-2-STD-CBL-5M
- SENSU-2-STD-CBL-20M
- SENSU-2-STD-CBL-50M



NOSE CONFIGURATION OPTIONS

TRANSVERSE

RIGHT ANGLED

STRAIGHT



PART NUMBER	RANGE	DESCRIPTION	FREQ	NOSE CONFIG	COVERAGE
ACFM-TMRA005-22; ACFM-TMRA005-GS-22	SENSU 2	Right-Angled Pencil Probe (GS: for galvanized steel)	5kHz	Mini - RA	15
ACFM-TMST005-22; ACFM-TMST005-GS-22	SENSU 2	Straight Pencil Probe (GS: for galvanized steel)	5kHz	Mini - Straight	15
ACFM-TMTR005-22; ACFM-TMTR005-GS-22	SENSU 2	Transverse Pencil Probe (GS: for galvanized steel)	5kHz	Mini - Transverse	15
ACFM-TMRA050-22	SENSU 2	Right-Angled Pencil probe	50kHz	Mini - RA	15
ACFM-TMST050-22	SENSU 2	Straight Pencil probe	50kHz	Mini - Straight	15
ACFM-TMTR050-22	SENSU 2	Transverse Pencil probe	50kHz	Mini - Transverse	15

COMPATIBLE WITH	APPLICATIONS	BENEFITS
AMIGO 2	Restricted area weld inspection, rat holes, plate edges, longitudinal cracks, circumferential cracks.	Eases inspection access in restricted areas.

SENSU 2 UNDERWATER ACFM PROBES

INTRODUCTION

Eddyfi's functional design philosophy continues in the new and innovative ACFM® probe range SENSU 2, which partners Amigo2 and U41 to enable much faster inspections, pristine signals, and higher SNR.

As "intelligent" probes, the SENSU™2 range stores configuration information onboard in the probe electronics.

- Faster than the previous legacy probes – 2 outputs
- Rated IP68 down to 300m (984ft) underwater
- All probe data stored in the probe's memory.
- Familiar probe bodies with updated electronics, cables and connectors
- Integrated cable options:
 - U41 compatible, watertight connector, 5m (16ft) long
 - Amigo 2 compatible, topside connector, 50m (164ft) long Rated IP68 down to 300m (984ft) underwater



SENSU 2 DIVER MINI ARRAY PROBE

COMPATIBLE WITH AMIGO 2 AND U41

- Flat, wide coverage array probe for ferritic welds; X field only
- 4 ACFM rows
- Coverage: 36mm (1.4in)

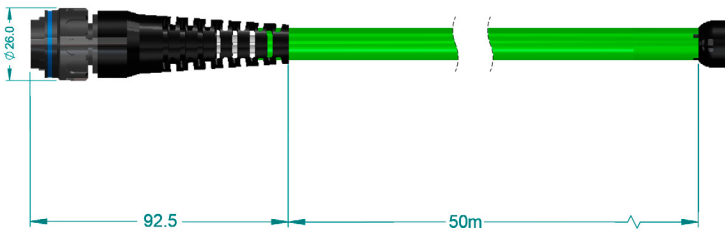
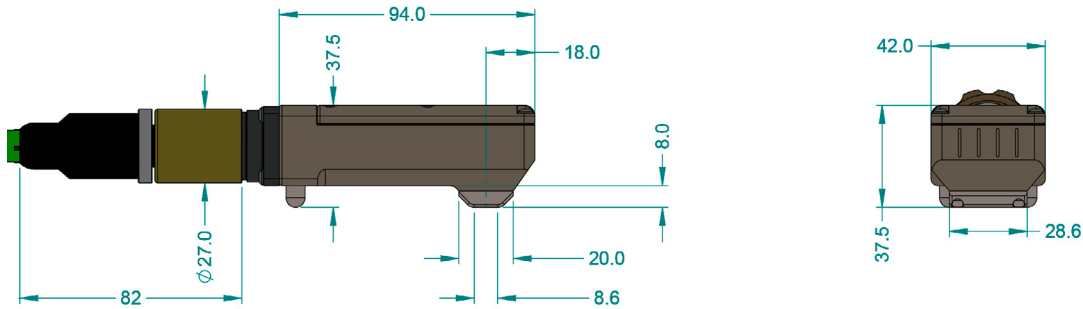

Amigo 2 50m (164ft) cable

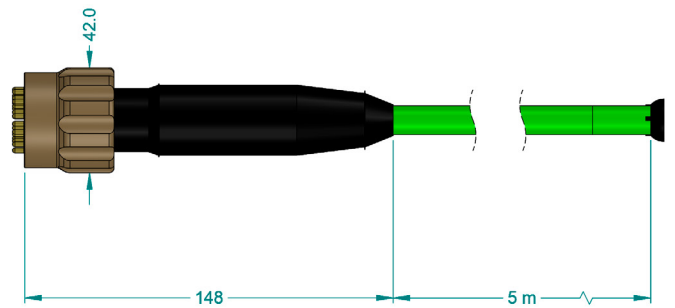

U41 5m (16.4ft) cable

PART NUMBER	RANGE	DESCRIPTION	FREQ	NOSE CONFIG	COVERAGE
ACFM-UMLP005-04X-40-50	SENSU 2	UW Diver Mini Array probe (Amigo 2)	5kHz	Mini	36
ACFM-UMLP005-04X-21-05	SENSU 2	UW Diver Mini Array probe (U41)	5kHz	Mini	36

COMPATIBLE WITH	APPLICATIONS	BENEFITS
AMIGO2 and U41 (versions compatible with array probes)	Subsea welds including butt, fillet and nodal joints.	Increase coverage and speed of inspection. The broader scan coverage allows for a margin of error while positioning the probe, making it easier for the operator.

SENSU 2 WELD PROBE (UW)

COMPATIBLE WITH AMIGO 2 AND U41

The probe of choice for generic ferritic or austenitic weld inspection.

Designed for subsea inspection of welds, plate and tubulars.

The probe electronics are encapsulated in an in-line bottle in the cable about 30cm (11.8in) from the probe body.

Features stabilizers and a wider field. The wider field enables deeper sizing down to 25mm (0.98in) deep.

For the inspection of galvanized steel structures, probe variants with the "GS" designation should be used.

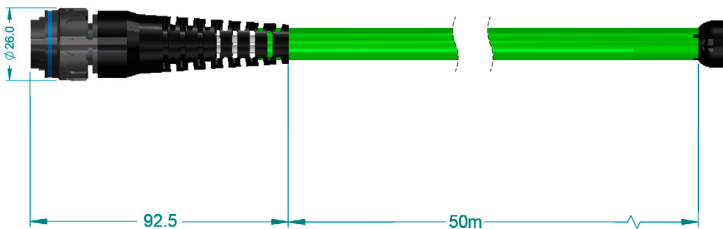
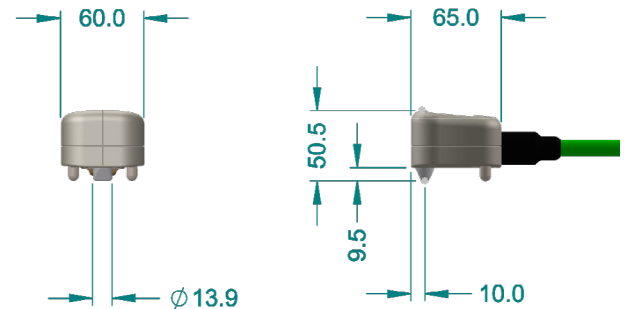

Amigo 2 50m (164ft) cable

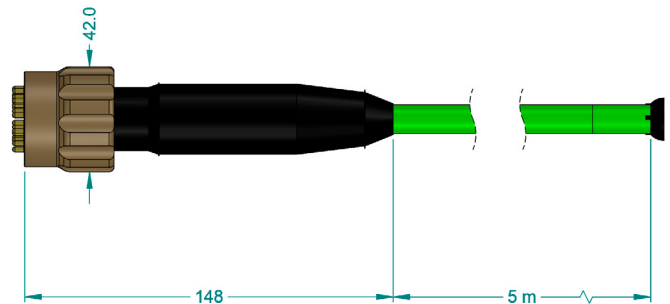

U41 5m (16.4ft) cable

PART NUMBER	RANGE	DESCRIPTION	FREQ	NOSE CONFIG	COVERAGE
ACFM-UMWP005-40-50; ACFM-UMWP005-GS-40-50	SENSU 2	UW Weld Probe, Amigo 2, 50m (164ft) cable (GS: for galvanized steel)	5kHz	Mini	15
ACFM-UMWP050-40-50	SENSU 2	UW HF Weld probe, Amigo 2, 50m (164ft) cable	50kHz	Mini	15
ACFM-UMWP005-21-05; ACFM-UMWP005-GS-21-05	SENSU 2	UW Weld Probe, U41, 5m (16ft) cable (GS: for galvanized steel)	5kHz	Mini	15
ACFM-UMWP050-21-05	SENSU 2	UW HF Weld probe, U41, 5m (16ft) cable	50kHz	Mini	15

COMPATIBLE WITH	APPLICATIONS	BENEFITS
AMIGO 2, U41D	Welds, plates, tubulars, through coating inspection, splash zone inspections.	Stabilizers Wider field Coverage of 15mm (0.6in)

SENSU 2 DIVER GROUND WELD PROBE

COMPATIBLE WITH AMIGO 2 AND U41

The Ground Weld probe is designed with a long slender nose to fit into a weld repair grind to inspect for new or residual cracking within the grind.

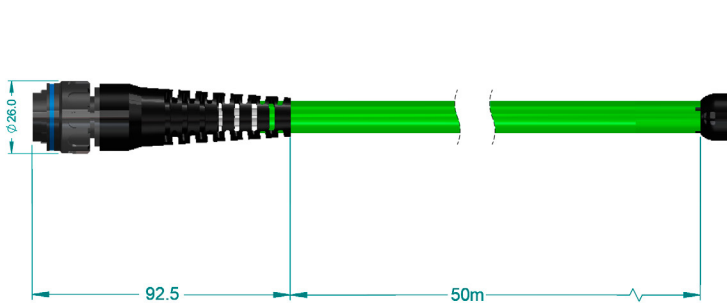
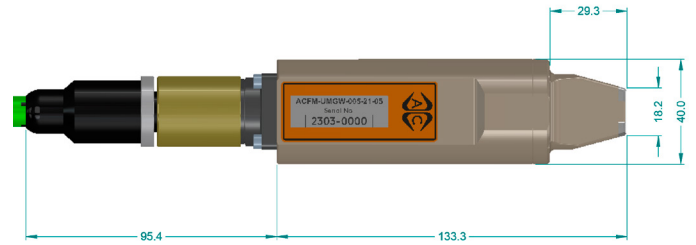
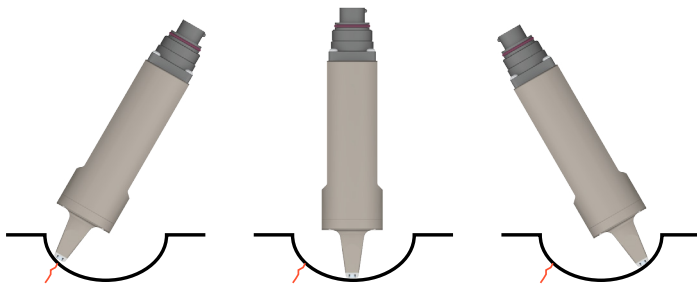

Amigo 2 50m (164ft) cable

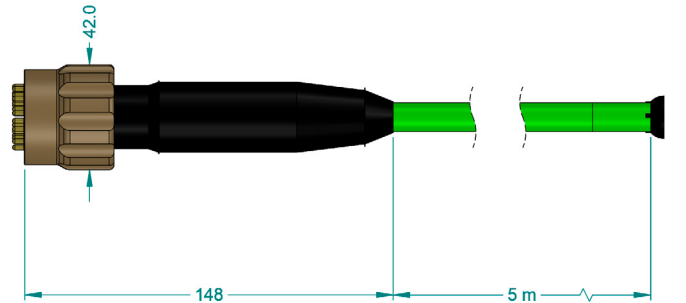

U41 5m (16.4ft) cable

PART NUMBER	RANGE	DESCRIPTION	FREQ	NOSE CONFIG	COVERAGE
ACFM-UMGW005-40-50	SENSU 2	UW Ground Weld probe (Amigo 2)	5kHz	Mini	15
ACFM-UMGW005-21-05	SENSU 2	UW Ground Weld probe (U41)	5kHz	Mini	15

COMPATIBLE WITH	APPLICATIONS	BENEFITS
AMIGO 2, U41D	Weld repair grind inspection, long nose.	Better reach into grounded welds. Enables surer weld repair through continuous monitoring throughout the repair process.

SENSU 2 TIGHT ACCESS PROBE (UW)

COMPATIBLE WITH AMIGO 2 AND U41

The Tight Access probe is designed for subsea inspection of tubular welded connections where the chord to brace angle prevents the use of the standard weld probe.

NOTE: The probe relies on the tight geometry for efficient coupling of the input field and so should only be used in these situations.

For the inspection of galvanized steel structures, probe variants with the "GS" designation should be used.

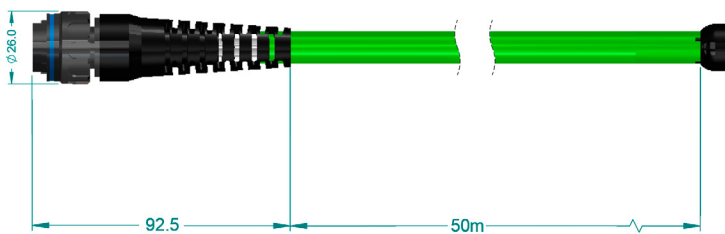
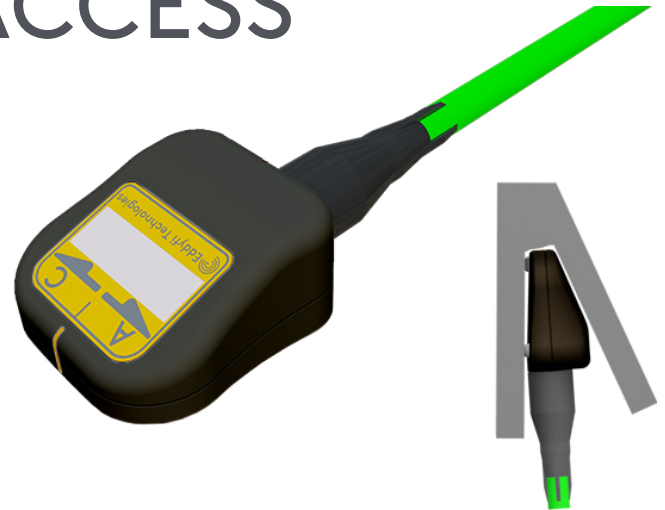

Amigo 2 50m (164ft) cable

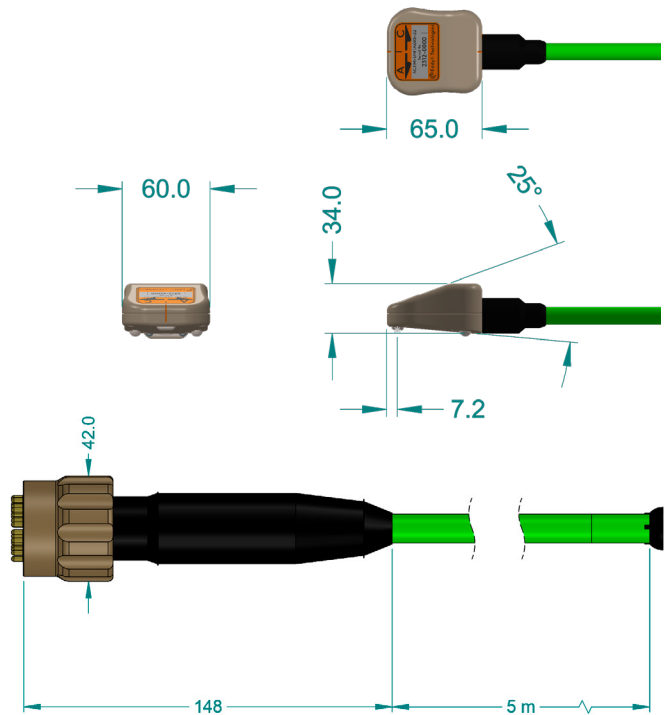

U41 5m (16.4ft) cable

PART NUMBER	RANGE	DESCRIPTION	FREQ	NOSE CONFIG	COVERAGE
ACFM-UMTA005-40-50; ACFM-UMTA005-GS-40-50	SENSU 2	UW Tight Access Probe, Amigo 2, 50m (164ft) cable (GS: for galvanized steel)	5kHz	Mini	15
ACFM-UMTA050-40-50	SENSU 2	UW HF Tight Access probe, Amigo 2, 50m (164ft) cable	50kHz	Mini	15
ACFM-UMTA005-21-05; ACFM-UMTA005-GS-21-05	SENSU 2	UW Tight Access Probe, U41, 5m (16ft) cable (GS: for galvanized steel)	5kHz	Mini	15
ACFM-UMTA050-21-05	SENSU 2	UW HF Tight Access probe, U41, 5m (16ft) cable	50kHz	Mini	15

COMPATIBLE WITH	APPLICATIONS	BENEFITS
AMIGO 2, U41D	Tubular welded connections, tight geometry.	Easier inspection of narrow geometries and restricted areas.

SENSU 2 MINI PENCIL PROBES (UW)

COMPATIBLE WITH AMIGO 2 AND U41

The Mini Pencil probe maintains the sensitivity of the normal Weld probes but have the advantage of being able to access restricted areas and areas of weld associated with rat holes or plate edges in structures.

Available nose configurations include straight, right angle, transverse.

For the inspection of galvanized steel structures, probe variants with the "GS" designation should be used.

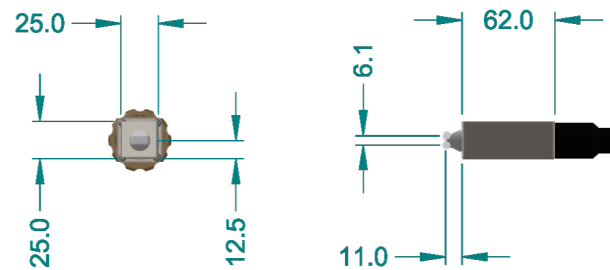
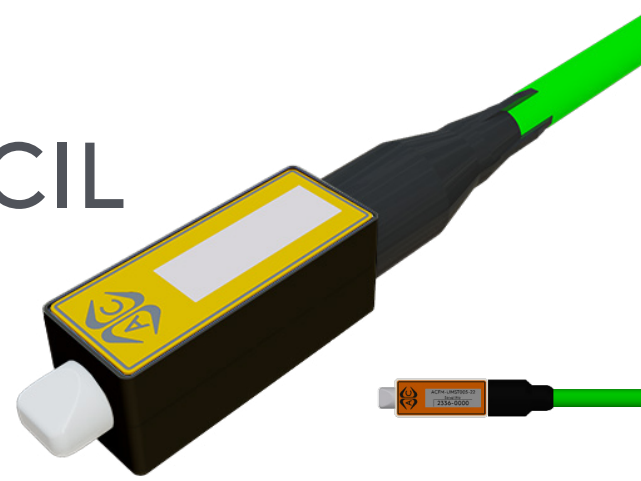

NOSE CONFIGURATION OPTIONS



PART NUMBER	RANGE	DESCRIPTION	FREQ	NOSE CONFIG	COVERAGE
ACFM-UMRA005-40-50; ACFM-UMRA005-GS-40-50	SENSU 2	UW Right-Angled Mini Pencil, Amigo 2, 50m (GS: for galvanized steel)	5kHz	Mini - RA	15
ACFM-UMST005-40-50; ACFM-UMST005-GS-40-50	SENSU 2	UW Straight Mini Pencil, Amigo 2, 50m (GS: for galvanized steel)	5kHz	Mini - Straight	15
ACFM-UMTR005-40-50; ACFM-UMTR005-GS-40-50	SENSU 2	UW Transverse Mini Pencil, Amigo 2, 50m (GS: for galvanized steel)	5kHz	Mini - Transverse	15
ACFM-UMRA050-40-50	SENSU 2	UW HF Right-Angled Mini Pencil, Amigo 2, 50m	50kHz	Mini - RA	15
ACFM-UMST050-40-50	SENSU 2	UW HF Straight Mini Pencil, Amigo 2, 50m	50kHz	Mini - Straight	15
ACFM-UMTR050-40-50	SENSU 2	UW HF Transverse Mini Pencil, Amigo 2, 50m	50kHz	Mini - Transverse	15
ACFM-UMST005-21-05; ACFM-UMST005-GS-21-05	SENSU 2	UW Straight Mini Pencil, U41, 5m (GS: for galvanized steel)	5kHz	Mini - Straight	15
ACFM-UMRA005-21-05; ACFM-UMRA005-GS-21-05	SENSU 2	UW Right-Angled Mini Pencil, U41, 5m (GS: for galvanized steel)	5kHz	Mini - RA	15
ACFM-UMTR005-21-05; ACFM-UMTR005-GS-21-05	SENSU 2	UW Transverse Mini Pencil, U41, 5m (GS: for galvanized steel)	5kHz	Mini - Transverse	15
ACFM-UMRA050-21-05	SENSU 2	UW HF Right-Angled Mini Pencil, U41, 5m	50kHz	Mini - RA	15
ACFM-UMST050-21-05	SENSU 2	UW HF Straight Mini Pencil, U41, 5m	50kHz	Mini - Straight	15
ACFM-UMTR050-21-05	SENSU 2	UW HF Transverse Mini Pencil, U41, 5m	50kHz	Mini - Transverse	15

COMPATIBLE WITH	APPLICATIONS	BENEFITS
AMIGO 2, U41D	Restricted areas, rat holes, plate edges.	Eases inspection access in restricted areas in splash zone, shallow depth, diver deployed.

SENSU 2 MICRO PENCIL PROBES (UW)

COMPATIBLE WITH AMIGO 2 AND U41

The Micro Pencil probes are similar to the Mini Pencil probes but are manufactured with high sensitivity coils for the detection and measurement of shallow defects, less than 1mm (0.04in) deep.

Designed for specialist applications where more sensitivity is required, but inspection surfaces need to be cleaner.

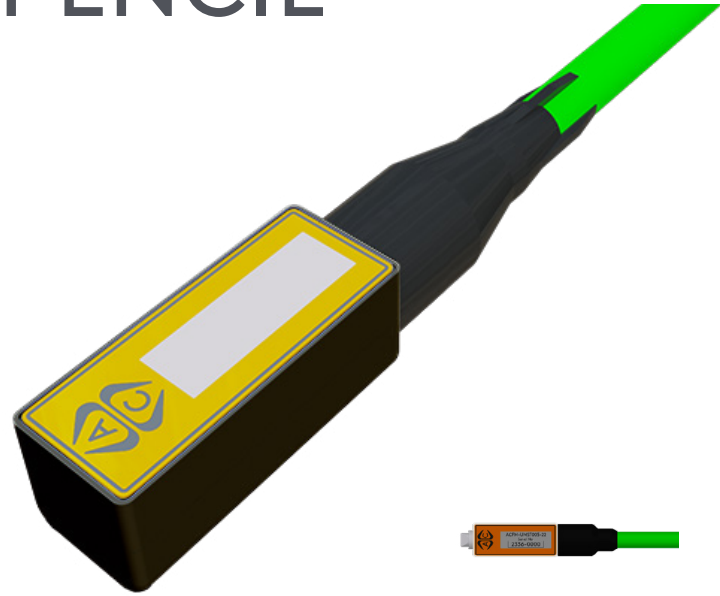

NOSE CONFIGURATION OPTIONS

TRANSVERSE



RIGHT ANGLED



STRAIGHT

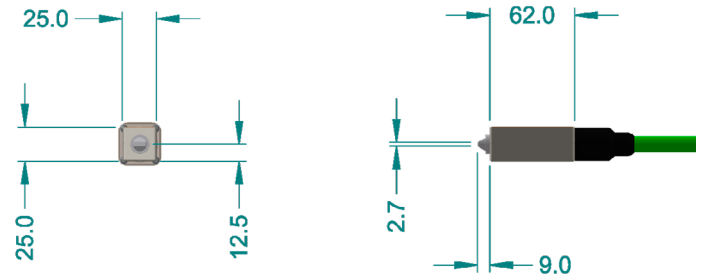

PART NUMBER	RANGE	DESCRIPTION	FREQ	NOSE CONFIG	COVERAGE
ACFM-UURA005-21-05	SENSU 2	UW Right-Angled Micro Nosed Pencil probe, Amigo 2, 50m	5kHz	Mini - RA	10
ACFM-UUST005-21-05	SENSU 2	UW Straight Micro Nosed Pencil probe, Amigo 2, 50m	5kHz	Mini - Straight	10
ACFM-UUTR005-21-05	SENSU 2	UW Transverse Micro Nosed Pencil probe, Amigo 2, 50m	5kHz	Mini - Transverse	10
ACFM-UURA050-21-05	SENSU 2	UW HF Right-Angled Micro Nosed Pencil probe, Amigo 2, 50m	50kHz	Mini - RA	10
ACFM-UUST050-21-05	SENSU 2	UW HF Straight Micro Nosed Pencil probe, Amigo 2, 50m	50kHz	Mini - Straight	10
ACFM-UUTR050-21-05	SENSU 2	UW HF Transverse Micro Nosed Pencil probe, Amigo 2, 50m	50kHz	Mini - Transverse	10
ACFM-UURA005-40-50	SENSU 2	UW Right-Angled Micro Nosed Pencil probe, U41, 5m	5kHz	Mini - RA	10
ACFM-UUST005-40-50	SENSU 2	UW Straight Micro Nosed Pencil probe, U41, 5m	5kHz	Mini - Straight	10
ACFM-UUTR005-40-50	SENSU 2	UW Transverse Micro Nosed Pencil probe, U41, 5m	5kHz	Mini - Transverse	10
ACFM-UURA050-40-50	SENSU 2	UW Right-Angled Micro Nosed Pencil probe, U41, 5m	50kHz	Mini - RA	10
ACFM-UUST050-40-50	SENSU 2	UW Straight Micro Nosed Pencil probe, U41, 5m	50kHz	Mini - Straight	10
ACFM-UUTR050-40-50	SENSU 2	UW Transverse Micro Nosed Pencil probe, U41, 5m	50kHz	Mini - Transverse	10

COMPATIBLE WITH	APPLICATIONS	BENEFITS
AMIGO 2, U41D	High sensitivity for shallow defects (<1mm/0.04in)	Eases inspection access in restricted areas.

ACFM PROBE LIST

PART NUMBER	DESCRIPTION	FREQ	COVERAGE	AMIGO2	AMIGO2 SE	U41
ACFM-TMRA005-22	ACFM® Sensu2 right-angled pencil probe, 5kHz	5KHz	15mm (0.6in)	Y	Y	N
ACFM-TMRA050-22	ACFM® Sensu2 right-angled pencil probe, 50kHz	50KHz	15mm (0.6in)	Y	Y	N
ACFM-TMST005-22	ACFM® Sensu2 straight pencil probe, 5kHz	5KHz	15mm (0.6in)	Y	Y	N
ACFM-TMST050-22	ACFM® Sensu2 straight pencil probe, 50kHz	50KHz	15mm (0.6in)	Y	Y	N
ACFM-TMTR005-22	ACFM® Sensu2 trans pencil probe, 5kHz	5KHz	15mm (0.6in)	Y	Y	N
ACFM-TMTR050-22	ACFM® Sensu2 trans pencil probe, 50kHz	50KHz	15mm (0.6in)	Y	Y	N
ACFM-TMWP005-22	ACFM® Sensu2 weld probe, 5kHz	5KHz	15mm (0.6in)	Y	Y	N
ACFM-TUCA005-16T-40	ACFM® Sensu2 compliant array probe, 5kHz, 16 rows	5KHz	90mm (3.5in)	Y	N	N
ACFM-TUCA005-8T-40	ACFM® Sensu2 compliant array probe, 5kHz, 8 rows	5KHz	45mm (1.8in)	Y	N	N
ACFM-UMGW005-40-50	ACFM® Sensu2 UW ground weld probe 5kHz, 50m	5KHz	15mm (0.6in)	Y	Y	N
ACFM-UMLP005-04X-40-50	ACFM® Sensu2 UW diver mini array probe 5kHz, 50m	5KHz	36mm (1.4in)	Y	N	N
ACFM-UMRA005-40-50	ACFM® Sensu2 UW right-ang mini pencil probe 5kHz 50m	5KHz	15mm (0.6in)	Y	Y	N
ACFM-UMRA050-40-50	ACFM Sensu2 UW HF right-angled mini pencil probe 50m	50KHz	15mm (0.6in)	Y	Y	N
ACFM-UMST005-40-50	ACFM® Sensu2 UW straight mini pencil probe 5kHz, 50m	5KHz	15mm (0.6in)	Y	Y	N
ACFM-UMST050-40-50	ACFM® Sensu2 UW HF straight mini pencil probe, 50m	50KHz	15mm (0.6in)	Y	Y	N
ACFM-UMTA005-40-50	ACFM® Sensu2 UW Tight Access probe 5kHz, 50m	5KHz	15mm (0.6in)	Y	Y	N
ACFM-UMTA050-40-50	ACFM® Sensu2 UW HF Tight Access probe, 50m	50KHz	15mm (0.6in)	Y	Y	N
ACFM-UMTR005-40-50	ACFM® Sensu2 UW trans mini pencil probe 5kHz, 50m	5KHz	15mm (0.6in)	Y	Y	N
ACFM-UMTR050-40-50	ACFM® Sensu2 UW HF trans mini pencil probe, 50m	50KHz	15mm (0.6in)	Y	Y	N
ACFM-UMWP005-40-50	ACFM® Sensu2 UW weld probe 5kHz, 50m	5KHz	15mm (0.6in)	Y	Y	N
ACFM-UMWP050-40-50	ACFM® Sensu2 UW HF weld probe, 50m	50KHz	15mm (0.6in)	Y	Y	N
ACFM-UURA005-40-50	ACFM® Sensu2 UW right-ang micro pencil probe 5kHz 50m	5KHz	10mm (0.04in)	Y	Y	N
ACFM-UURA050-40-50	ACFM® Sensu2 UW HF right-ang micro pencil probe 50m	50KHz	10mm (0.04in)	Y	Y	N
ACFM-UUST005-40-50	ACFM® Sensu2 UW straight micro pencil probe 5kHz 50m	5KHz	10mm (0.04in)	Y	Y	N
ACFM-UUST050-40-50	ACFM® Sensu2 UW HF straight micro pencil probe 50m	50KHz	10mm (0.04in)	Y	Y	N
ACFM-UUTR005-40-50	ACFM® Sensu2 UW trans micro pencil probe 5kHz, 50m	5KHz	10mm (0.04in)	Y	Y	N
ACFM-UUTR050-40-50	ACFM® Sensu2 UW HF trans micro pencil probe 50m	50KHz	10mm (0.04in)	Y	Y	N
AMIGO2-3PROBES-KIT-50K	ACFM® Sensu2 50kHz, 3-probe kit for Amigo2	50KHz	15mm (0.6in)	Y	Y	N
AMIGO2-3PROBES-KIT-5K	ACFM® Sensu2 5kHz, 3-probe kit for Amigo2	5KHz	15mm (0.6in)	Y	Y	N
ACFM-TMXA005-03X-22	ACFM® Sensu2 straight mini array probe, 5kHz	5KHz	45mm (1.8in)	Y	N	N
ACFM-HMST005-22	ACFM® Sensu2 High temp. straight probe, 5kHz	5KHz	15mm (0.6in)	Y	N	N
ACFM-HMST050-22	ACFM® Sensu2 High temp. straight probe, 50kHz	50kHz	15mm (0.6in)	Y	N	N
ACFM-TNTP005-22	ACFM® Sensu2 Universal Thread probe, 5kHz	5KHz	10mm (0.04in)	Y	Y	N
ACFM-TNTP050-22	ACFM® Sensu2 Universal Thread probe, 50kHz	50kHz	10mm (0.04in)	Y	Y	N

ACFM PROBE LIST

PART NUMBER	DESCRIPTION	FREQ	COVERAGE	AMIGO2	AMIGO2 SE	U41
ACFM-UMGW005-21-05	ACFM® U41 Sensu2 UW ground weld probe, 5kHz	5KHz	15mm (0.6in)	N	N	Y
ACFM-UMLP005-04X-21-05	ACFM® U41 Sensu2 UW diver mini array probe, 5kHz	5KHz	36mm (1.4in)	N	N	Y
ACFM-UMRA005-21-05	ACFM® U41 Sensu2 UW right-ang mini pencil probe, 5kHz	5KHz	15mm (0.6in)	N	N	Y
ACFM-UMST005-21-05	ACFM® U41 Sensu2 UW straight mini pencil probe, 5kHz	5KHz	15mm (0.6in)	N	N	Y
ACFM-UMST050-21-05	ACFM® U41 Sensu2 UW HF straight mini pencil probe	50KHz	15mm (0.6in)	N	N	Y
ACFM-UMTA005-21-05	ACFM® U41 Sensu2 UW tight access probe, 5kHz	5KHz	15mm (0.6in)	N	N	Y
ACFM-UMTA050-21-05	ACFM® U41 Sensu2 UW HF tight access probe	50KHz	15mm (0.6in)	N	N	Y
ACFM-UMTR005-21-05	ACFM® U41 Sensu2 UW trans mini pencil probe, 5kHz	5KHz	15mm (0.6in)	N	N	Y
ACFM-UMTR050-21-05	ACFM® U41 Sensu2 UW HF trans mini pencil probe	50KHz	15mm (0.6in)	N	N	Y
ACFM-UMWP005-21-05	ACFM® U41 Sensu2 UW weld probe, 5kHz	5KHz	15mm (0.6in)	N	N	Y
ACFM-UMWP050-21-05	ACFM® U41 Sensu2 UW HF weld probe	50KHz	15mm (0.6in)	N	N	Y
ACFM-UURA005-21-05	ACFM® U41 Sensu2 UW right-ang micro pencil probe 5kHz	5KHz	10mm (0.04in)	N	N	Y
ACFM-UURA050-21-05	ACFM® U41 Sensu2 UW HF right-ang micro pencil probe	50KHz	10mm (0.04in)	N	N	Y
ACFM-UUST005-21-05	ACFM® U41 Sensu2 UW straight micro pencil probe, 5kHz	5KHz	10mm (0.04in)	N	N	Y
ACFM-UUST050-21-05	ACFM® U41 Sensu2 UW HF straight micro pencil probe	50KHz	10mm (0.04in)	N	N	Y
ACFM-UUTR005-21-05	ACFM® U41 Sensu2 UW trans micro pencil probe, 5kHz	5KHz	10mm (0.04in)	N	N	Y
ACFM-UUTR050-21-05	ACFM® U41 Sensu2 UW HF trans micro nosed pencil probe	50KHz	10mm (0.04in)	N	N	Y
ACFM-UW-5PROBES-KIT-D	ACFM® Sensu2 UW U41D 5kHz probe kit	5KHz		N	N	Y
ACFM-UW-5PROBES-KIT-DA	ACFM® Sensu2 UW U41DA 5kHz probe kit	5KHz		N	N	Y

The information in this document is accurate as of its publication. Actual products may differ from those presented herein. © 2023 Eddyfi Canada Inc. Amigo, ACFM and their associated logos are trademarks or registered trademarks of Eddyfi Technologies in the United States and/or other countries. Eddyfi Technologies reserves the right to change product offerings and specifications without notice. Eddyfi Technologies is a Previa Business Unit.

www.eddyfitechnologies.com

info@eddyfi.com

